

futuretogether

MEMORANDUM

Date: February 17, 2025
To: Alex M. Smith, Director of the Philadelphia Art Commission <Alex.Smith@Phila.gov>
Philadelphia Art Commission <ArtCommission@phila.gov>
From: Isaac J. Salm - Future Together LLC <isaac@letsfuturetogether.com>
Jaime Salm - Future Together LLC <jaime@letsfuturetogether.com>
cc: Elisa Ruse-Esposito, Philadelphia Parks & Recreation <Elisa.Ruse-Esposito@phila.gov>
Alyssa Young, Kaboom! <ayoung@kaboom.org>
Heidi Segall Levy, Watchdog <hsegalllevy@watchdogpm.com>
Sarah Lytle, Playful Learning Landscapes <stlytle@playfullearninglandscapes.fun>

Reference: Request for Administrative Approval – Fernhill Park Play Village

We respectfully request administrative approval for the installation of the Fernhill Park Play Village, an innovative interpretive play area located on the upper portion of Fernhill Park near the Morris Street entrance. This project is made possible through the generous support of Kaboom! and The William Penn Foundation and has been developed in collaboration with the Germantown community. The initiative is led by FutureTogether and the Friends of Fernhill Park, alongside the expert team from Playful Learning Landscapes, to align with the educational and play objectives outlined by our grant funding.

The Friends of Fernhill Park, a dedicated advocate and active community partner, has played a crucial role in guiding the design and ensuring a thoughtful balance between the needs of the neighborhood's children and the site's environmental and spatial constraints. The project transforms the underutilized yet cherished toddler track into an engaging Play Village. This installation is not a traditional playground but rather a collection of interactive and educational spaces that encourage creativity, learning, and imaginative play. The Play Village consists of five unique installations, each designed with a distinct educational and play objective while maintaining a cohesive aesthetic and design language.

1. Nature Stage – A dynamic space where children can act, perform, and engage in role-playing. This installation also provides opportunities for community-led programming, including performances, storytelling, and interactive events.
2. Riverbed Crossing – A creative interpretation of a natural riverbed, featuring a log crossing and a small boat structure. Cutouts of leaves are incorporated into the design, allowing children to engage in a nature-themed matching game. This installation also serves an

educational purpose, teaching children about the water cycle and how water travels from mountains to oceans, sustaining ecosystems like Fernhill Park.

3. Zig-Zag Beams – A series of balance beams with integrated cutout vowels (five beams) and embedded concrete consonants. This area encourages literacy-based play by challenging children to form words, while also offering opportunities for imaginative games such as the classic 'lava' game.
4. Play Village Facades – Three distinct interpretive play facades, each with unique interactive features:
 - o The first facade includes round “windows” that can be transformed into various imaginative settings, such as a plane, train, or spaceship.
 - o The second facade features two large abacuses, encouraging early math skills and interactive group play.
 - o The third facade integrates innovative tactile mazes, designed to stimulate sensory engagement and problem-solving.
5. Story Hills – A landscaped, dimensional space that invites children to climb, explore, and engage in storytelling activities. This area promotes creativity and literacy by encouraging children to share their own stories while learning the fundamental elements of storytelling.

This project represents a collaborative effort to enhance Fernhill Park by providing an engaging, educational, and community-driven play experience. The proposed Play Village aligns with the broader mission of Playful Learning Landscapes by integrating learning into everyday public spaces. We believe this installation will serve as a valuable asset to the Germantown community, fostering imaginative play, social interaction, and educational growth for children between the ages of 0 – 8 years old.

Thank you for your time and consideration. We look forward to your feedback and the opportunity to bring this innovative project to life.

Sincerely,

Isaac J. Salm
Future Together LLC, Business Director
O: 215-925-9359 EXT. 112
M: 305-815-8330
isaac@letsfuturetogether.com

Attachments: Site Plans, Process, Renderings, Technical Drawings

futuretogether

Fernhill Park Play Village Revisions

Fernhill Play Village

In Partnership with:

**William Penn
Foundation**



The information contained in this document is intended only for the personal and confidential use of the recipient(s). This document may contain privileged and confidential information and/or work product. If the reader of this document is not the intended recipient or an agent responsible for delivering it to the intended recipient, you are hereby notified that you have received this document in error and that any review, dissemination, distribution, or copying of this document is strictly prohibited.

The Site - Fernhill Park Toddler Track



AERIAL VIEW



MORRIS ST. ENTRANCE



TODDLER TRACK



TRACK CONDITION



PLAY VILLAGE HILL



ENTRY PATH VIEW

Our Process - Community Engagement & Co-Design



WORKSHOP 01



WORKSHOP 02

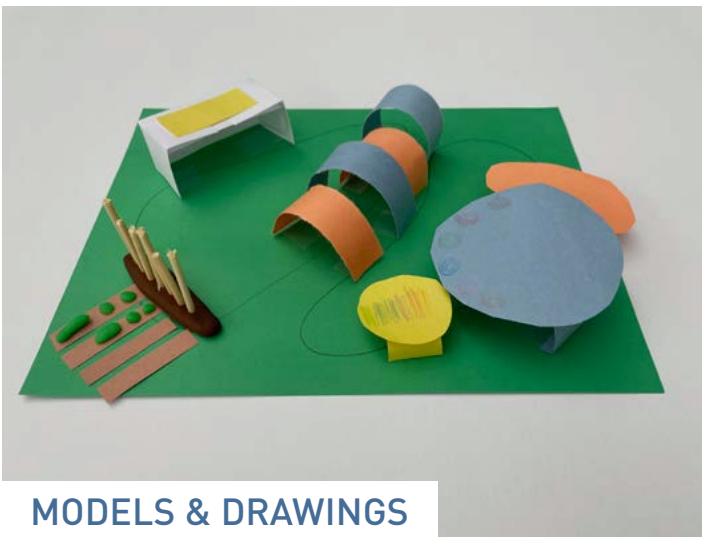

MODELS & DRAWINGS

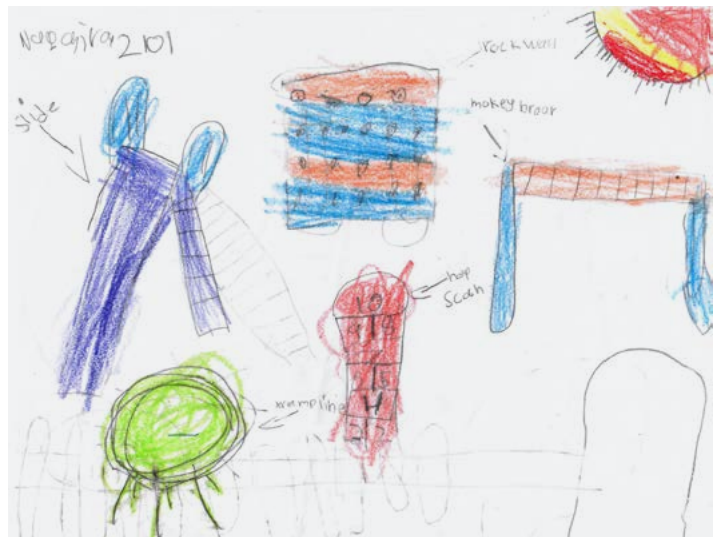

Our Process - Play Area Research & Precedents



Our Process - Community Selection

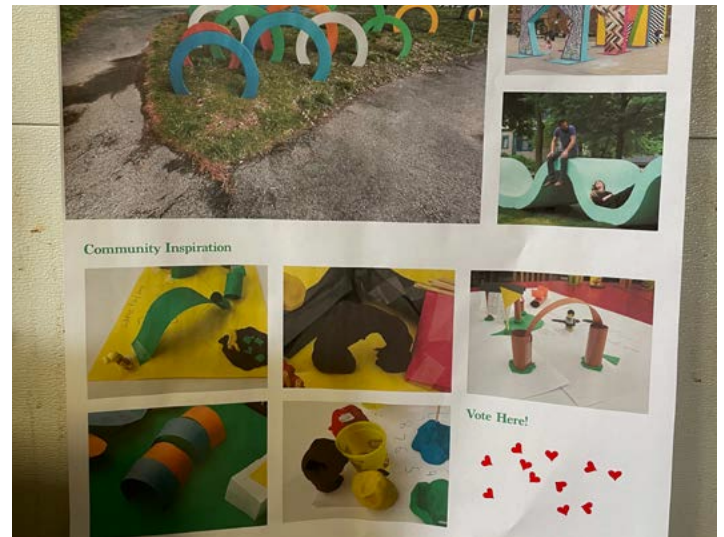

Fernhill Park Play Village - Proposed Layout

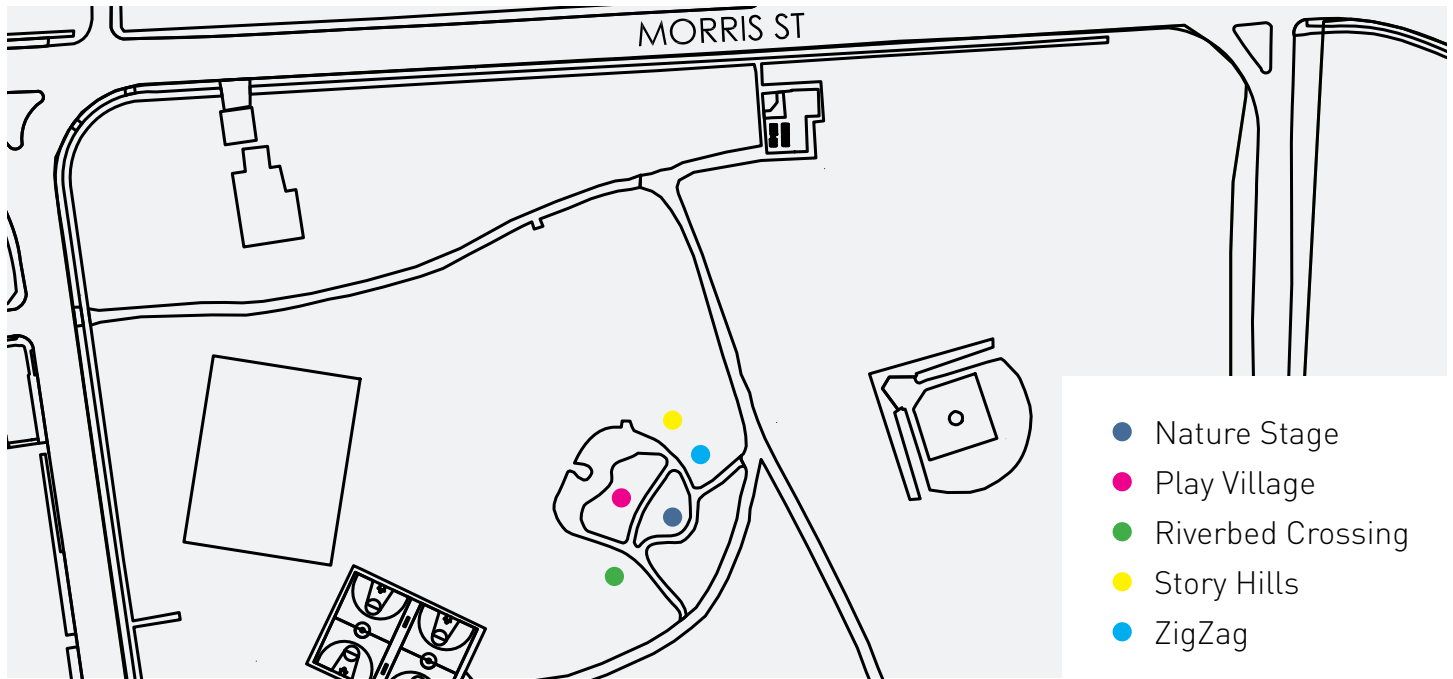

Nature Stage - Performance, Learning & Play

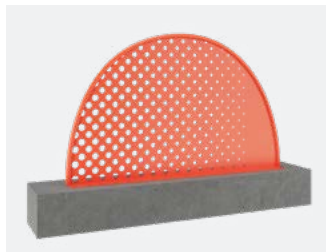
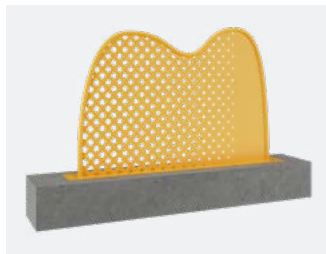

Nature Stage - Precedent



FDR Park



Northwood Park

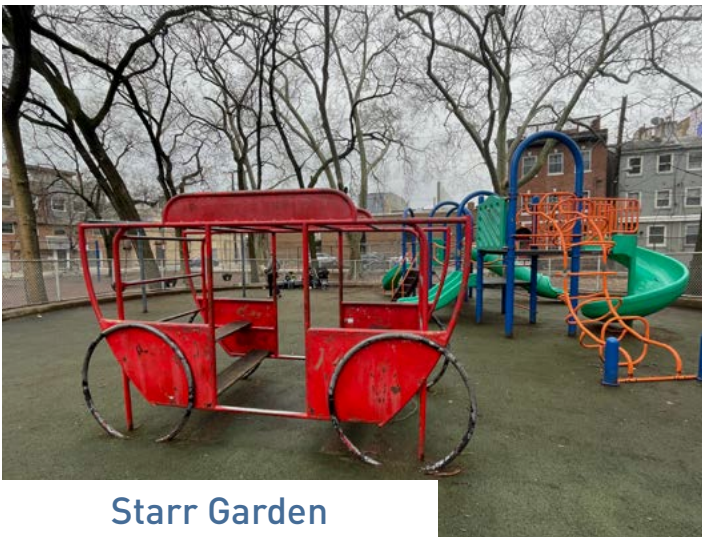

Starr Garden



Schuykill River Park



Hancock Playground



S. Phila. High School

Nature Stage - Stage Framing

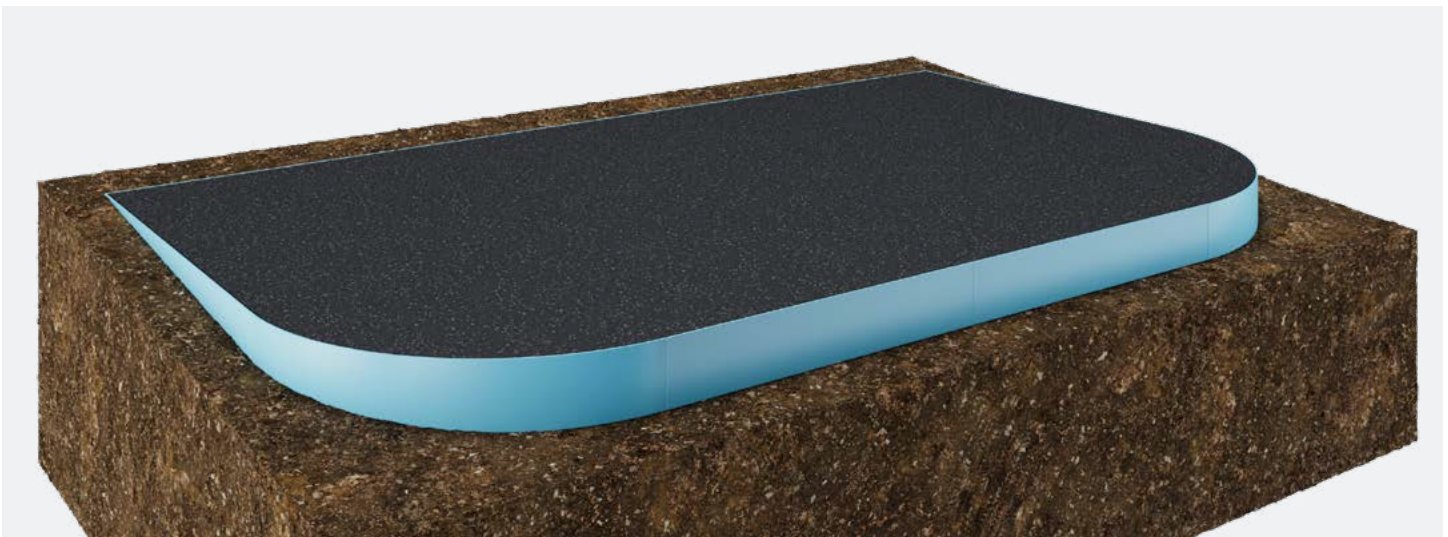
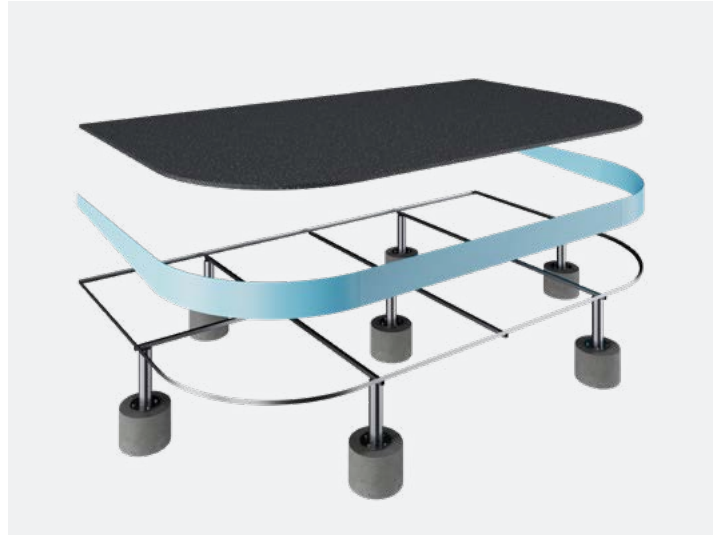
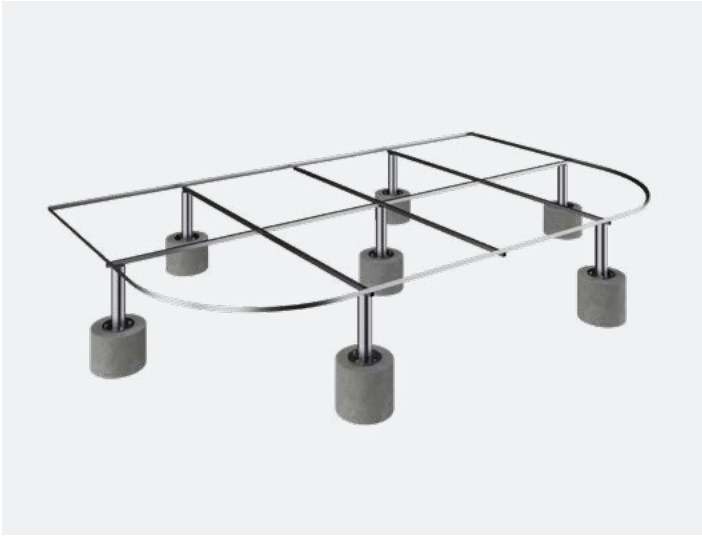

Nature Stage - Stage Backdrop Components Detail

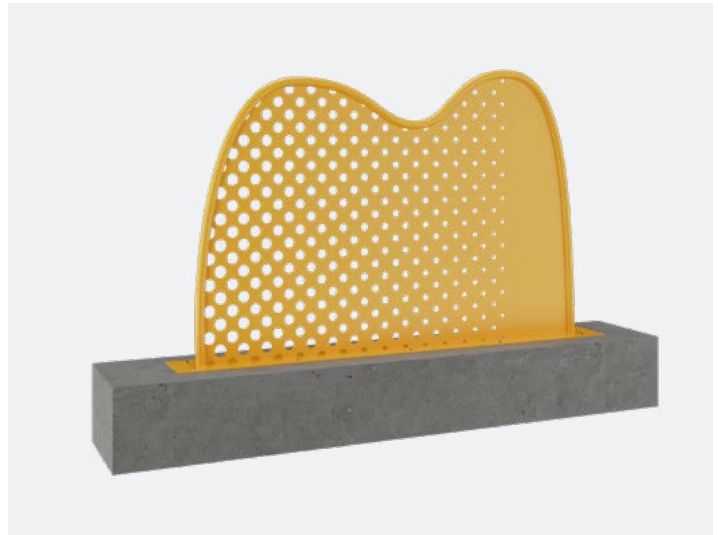
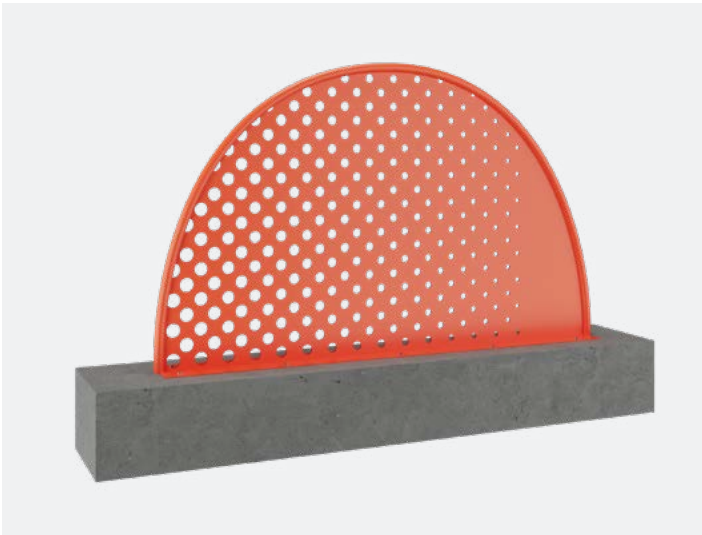
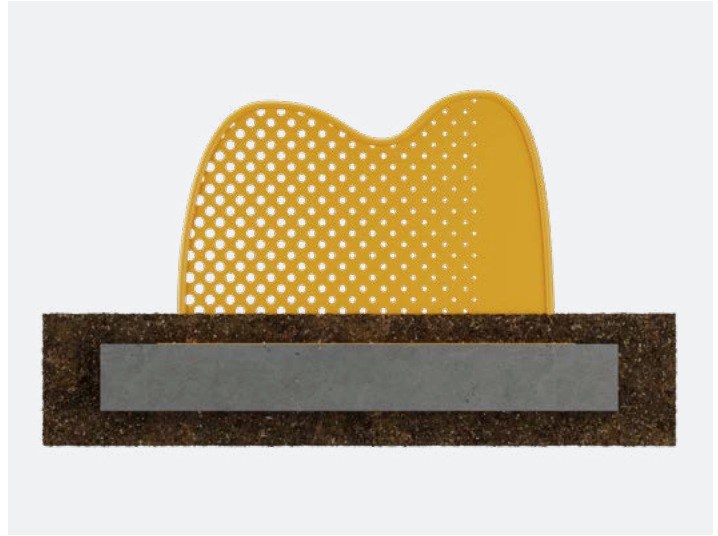

Nature Stage - Technical Drawings Overall Layout

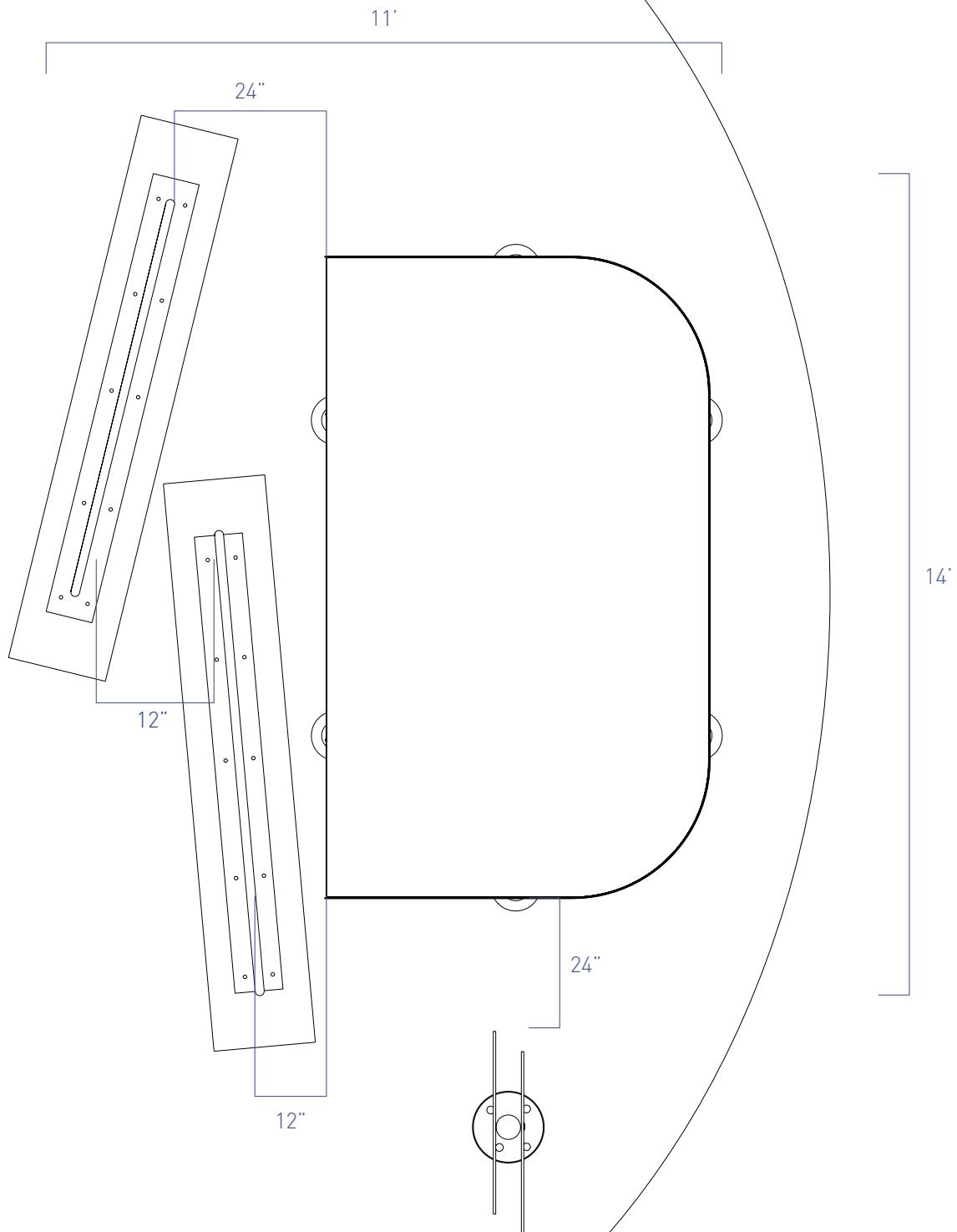

Nature Stage - Technical Drawings Stage Top View

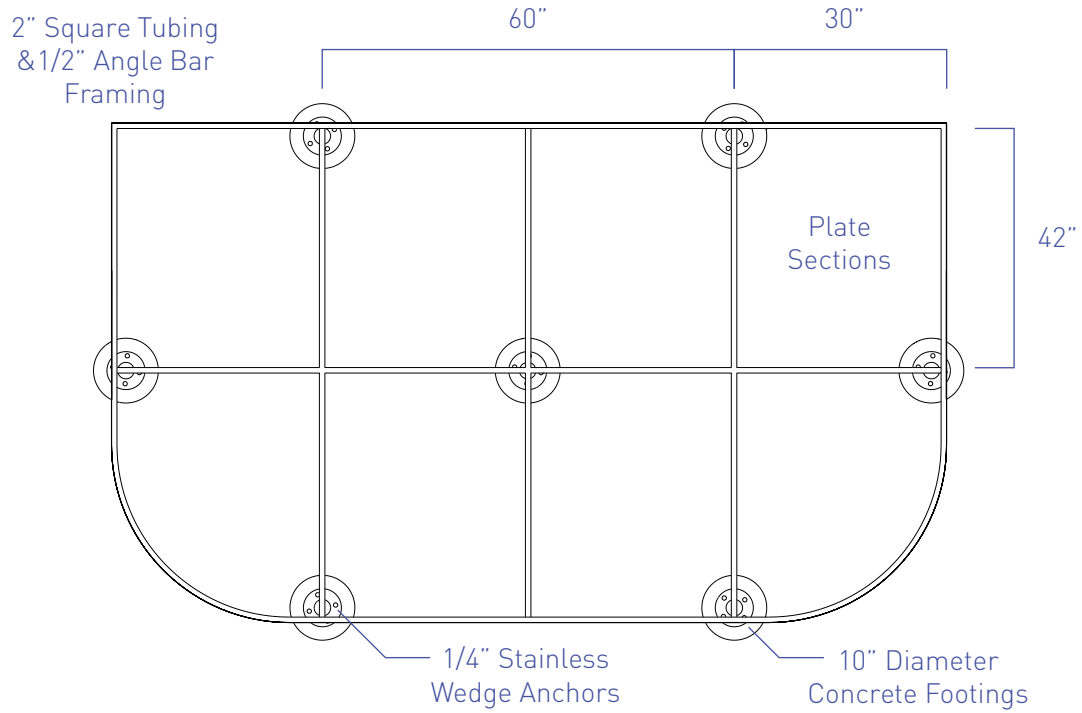

TOP VIEW ASSEMBLY

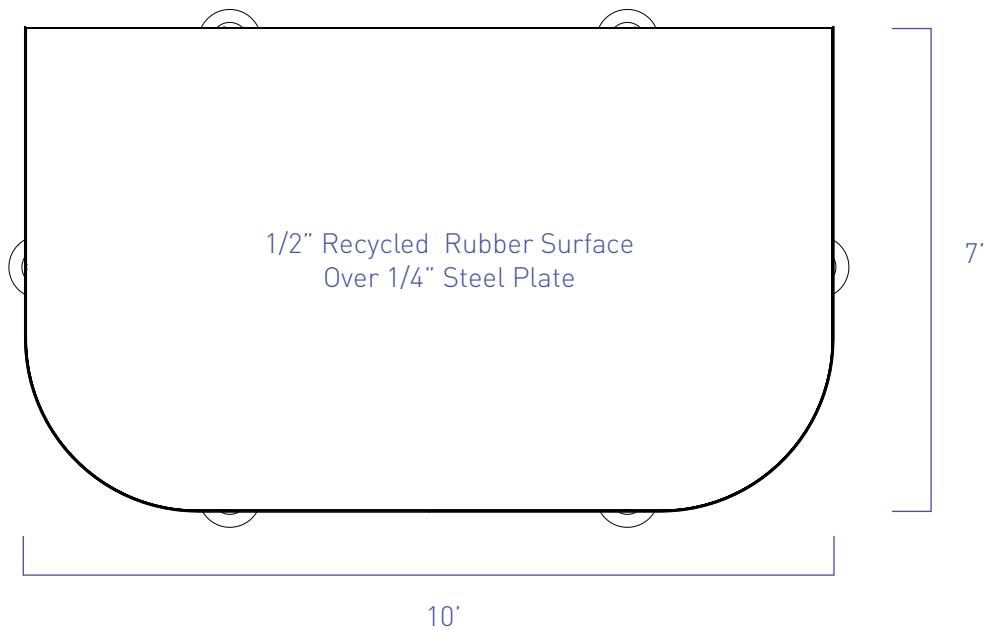

TOP VIEW

Nature Stage - Technical Drawings Stage Side & Front View

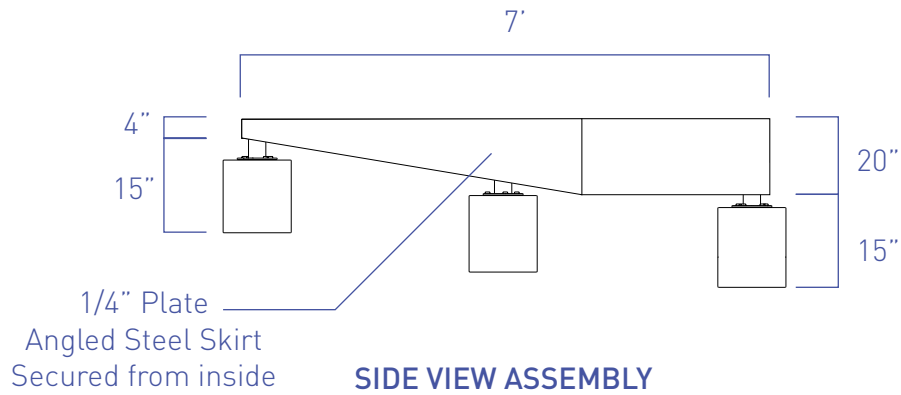
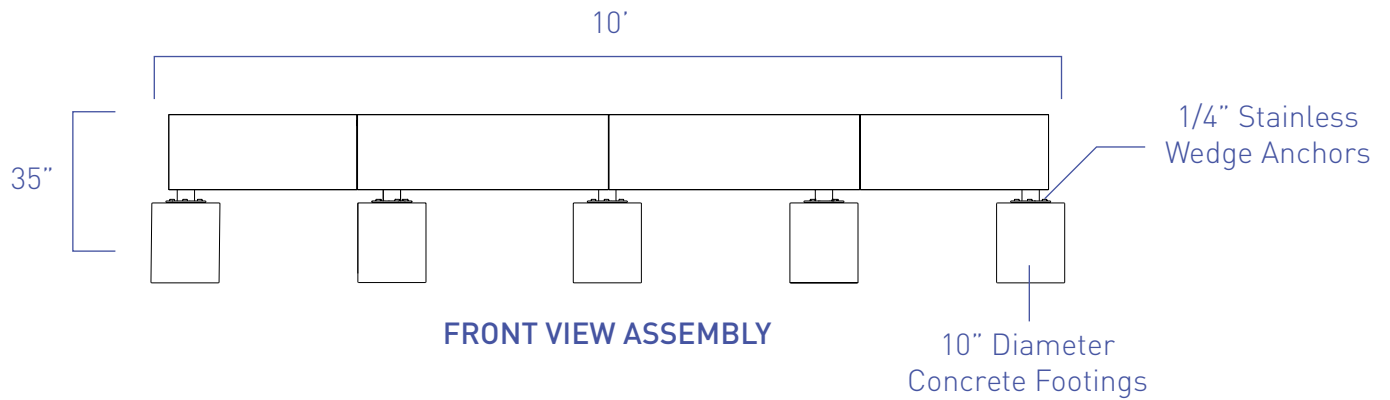

Nature Stage - Proposed Installation Stage

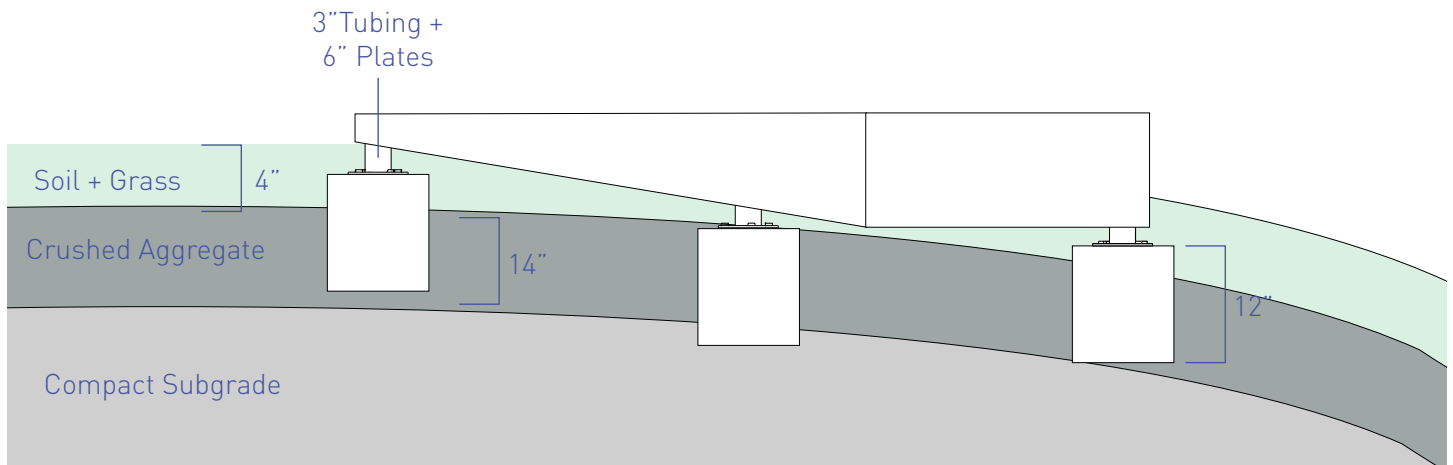

Nature Stage - Technical Drawings Round Backdrop

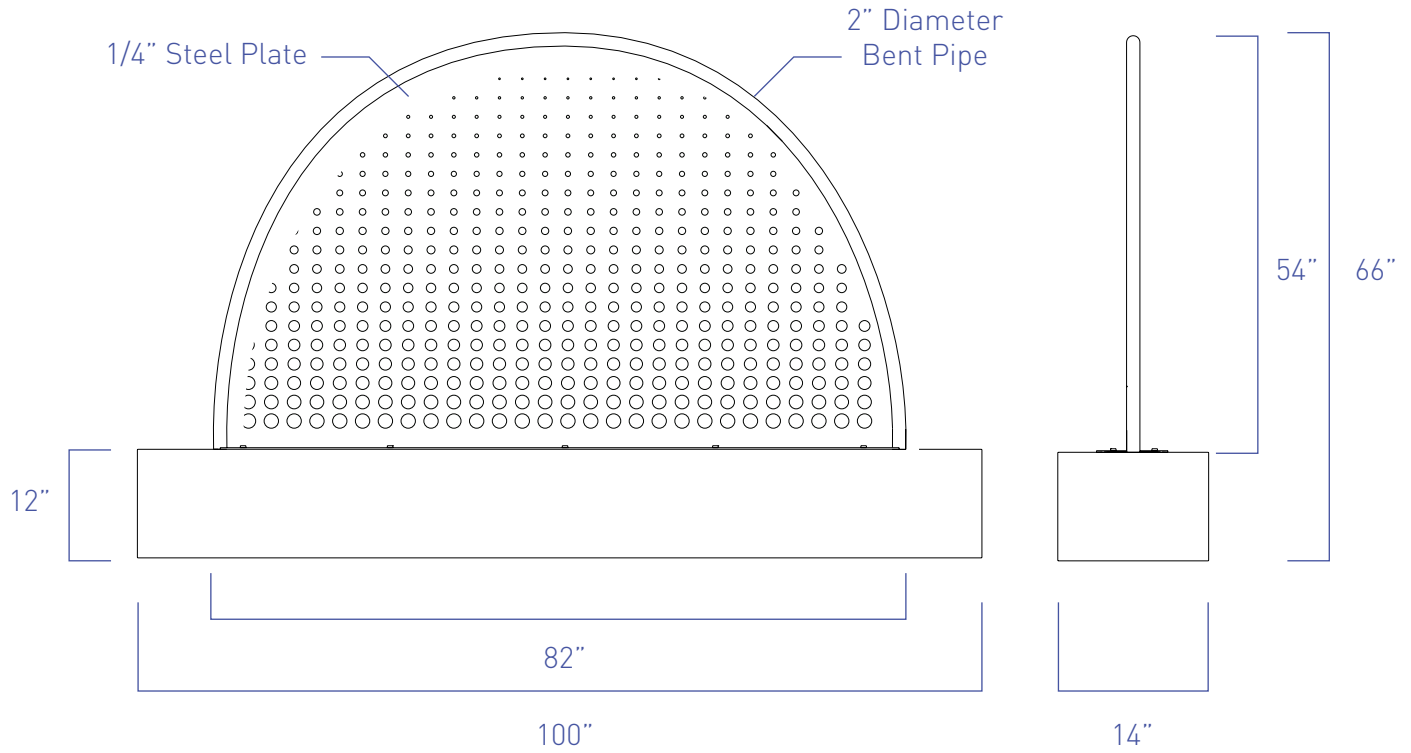

FRONT VIEWS

SIDE VIEW

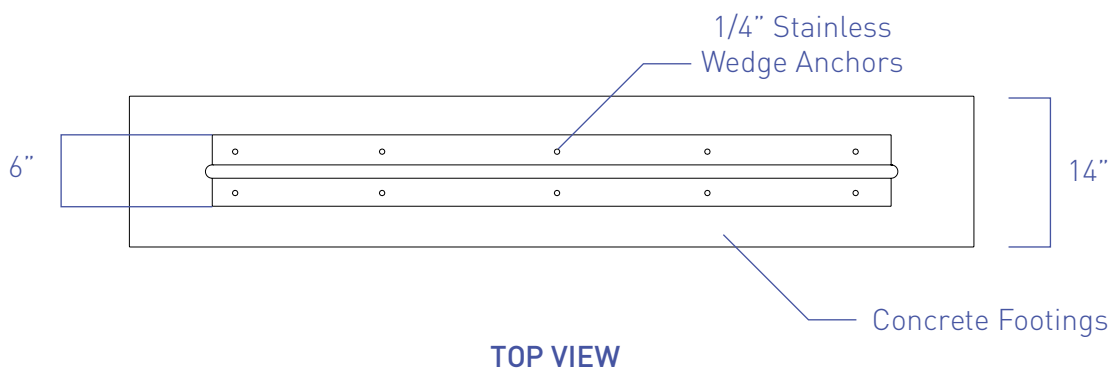

TOP VIEW

Nature Stage - Technical Drawings Squiggle Backdrop

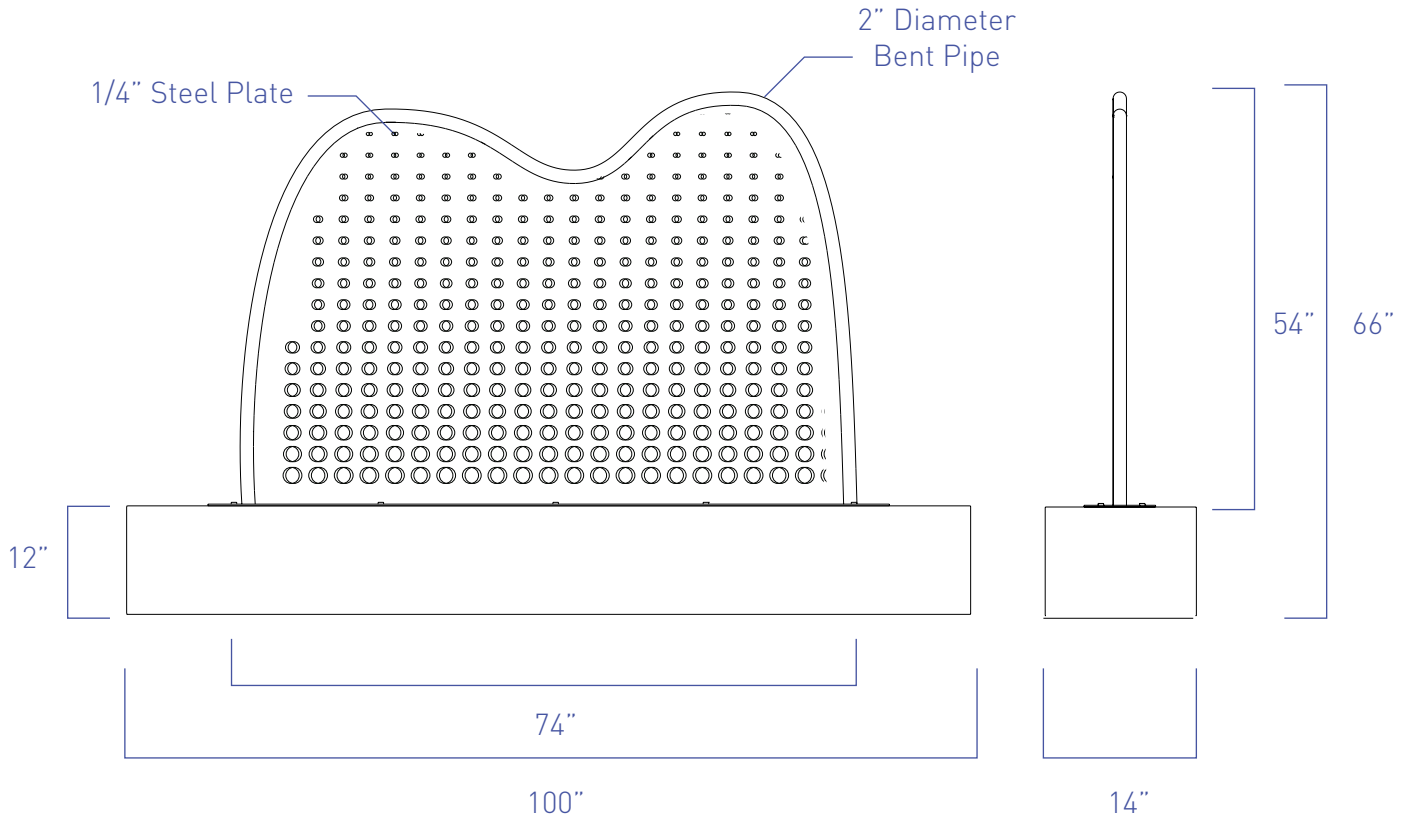

FRONT VIEWS

SIDE VIEW

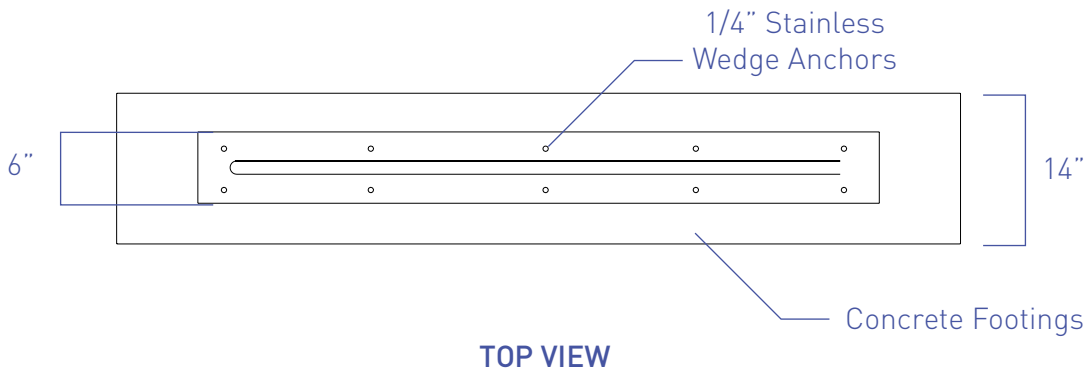

TOP VIEW

Nature Stage - Technical Drawings Squiggle Backdrop

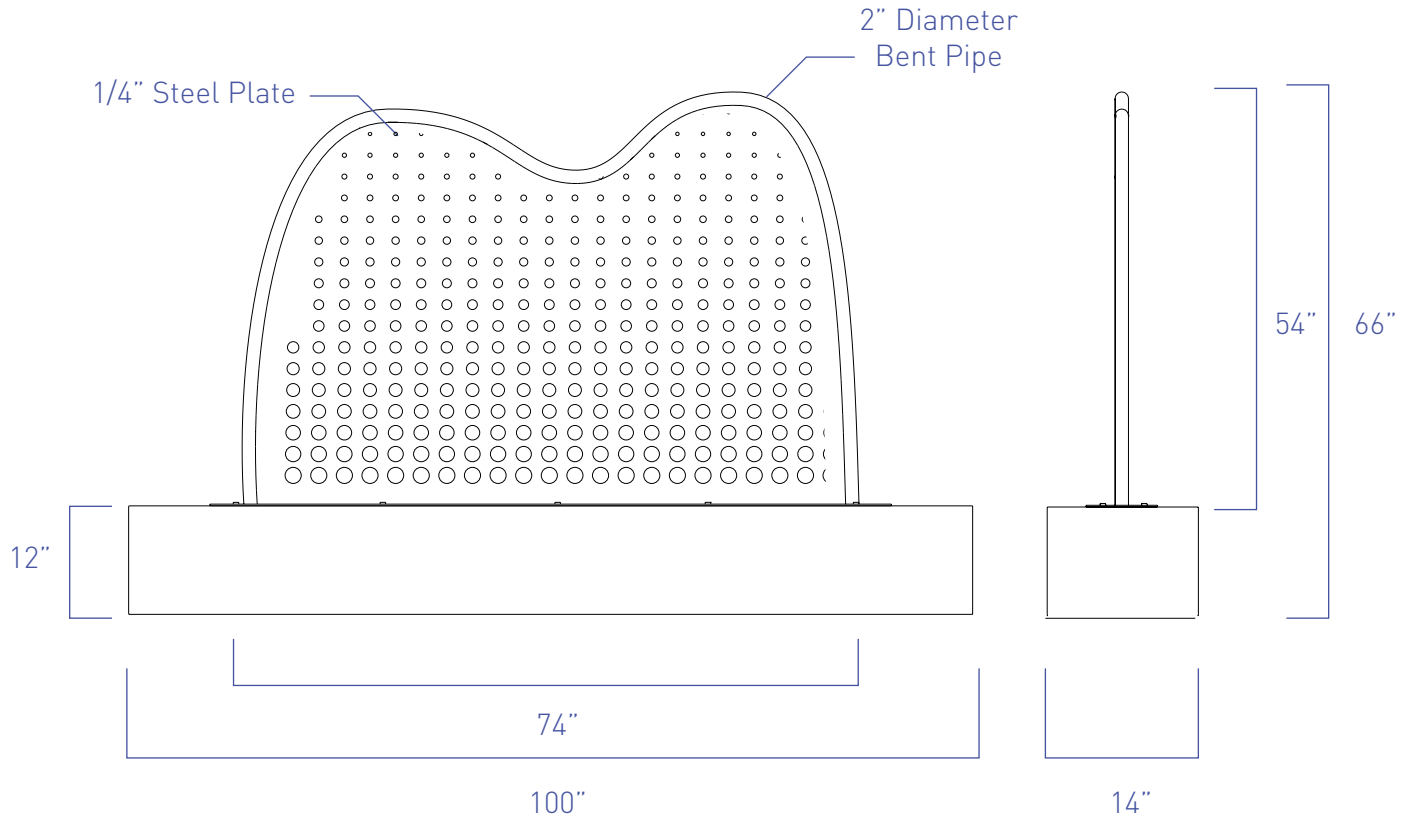

FRONT VIEWS

SIDE VIEW

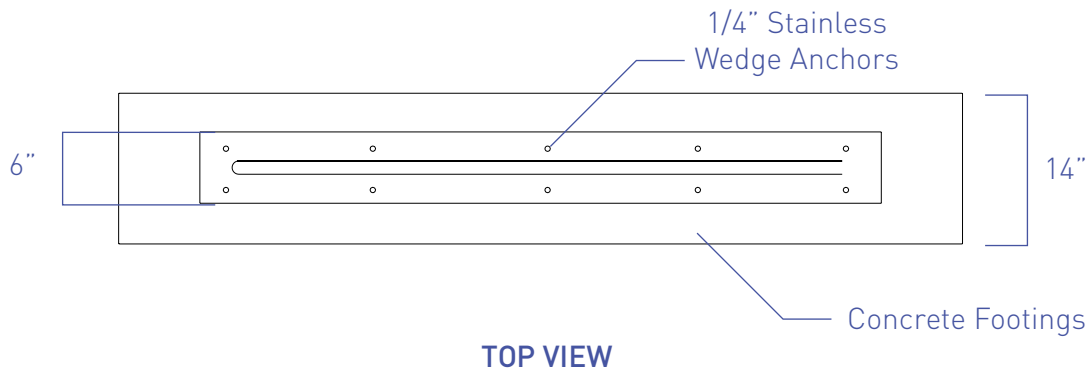

TOP VIEW

Nature Stage - Proposed Installation Method Backdrops

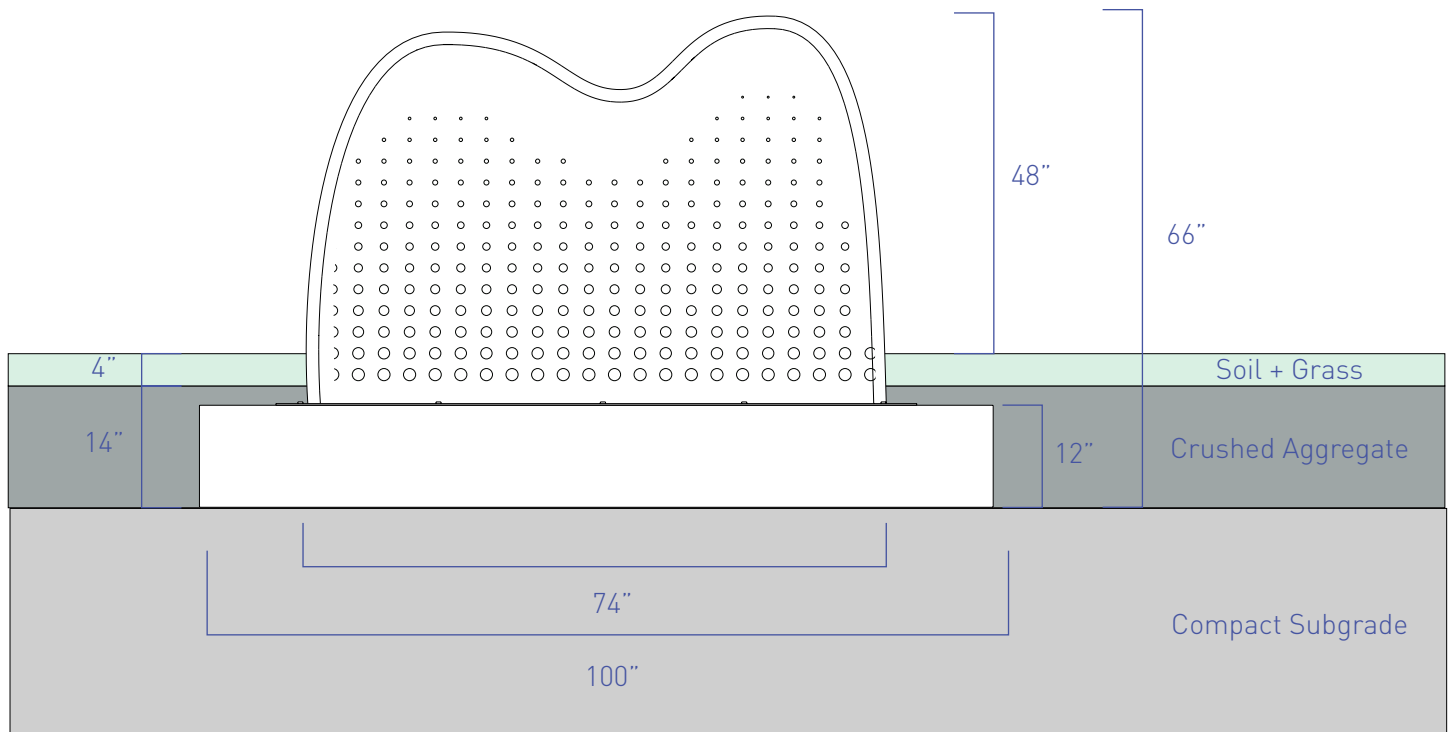
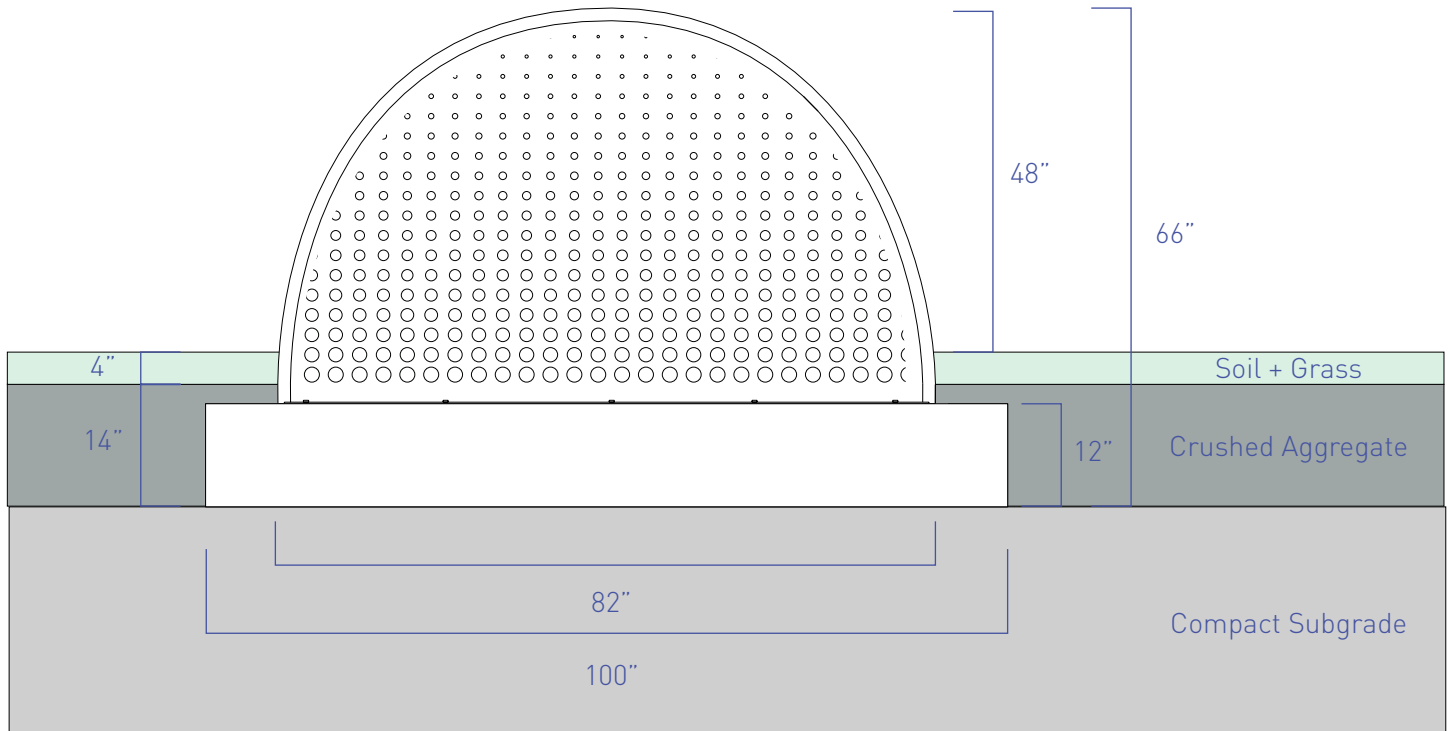

Riverbed Crossing - Discover Nature

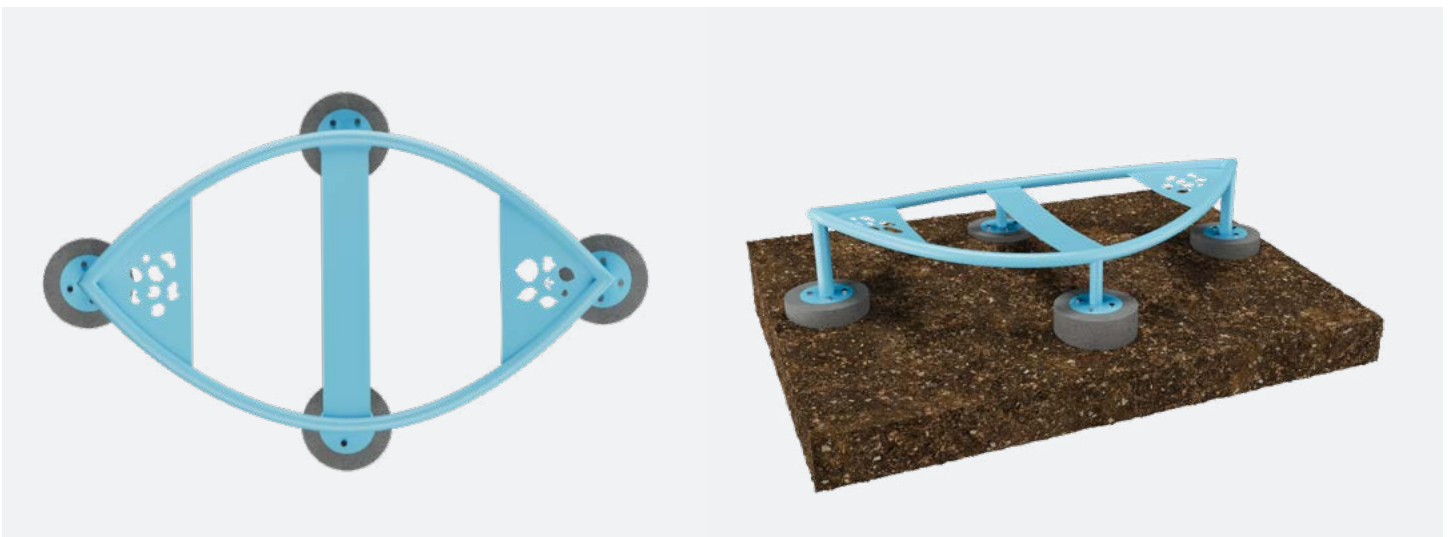

Nature Stage - Canoe Detail

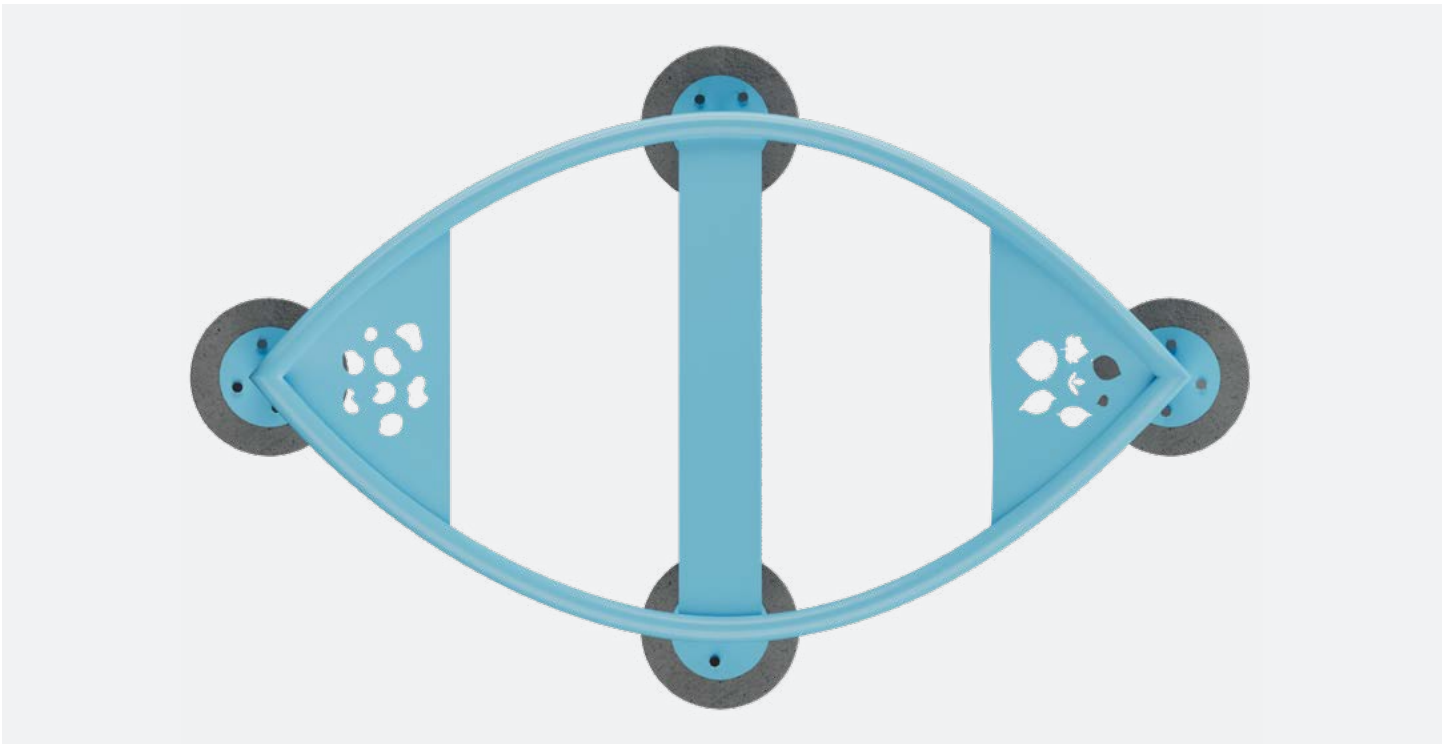
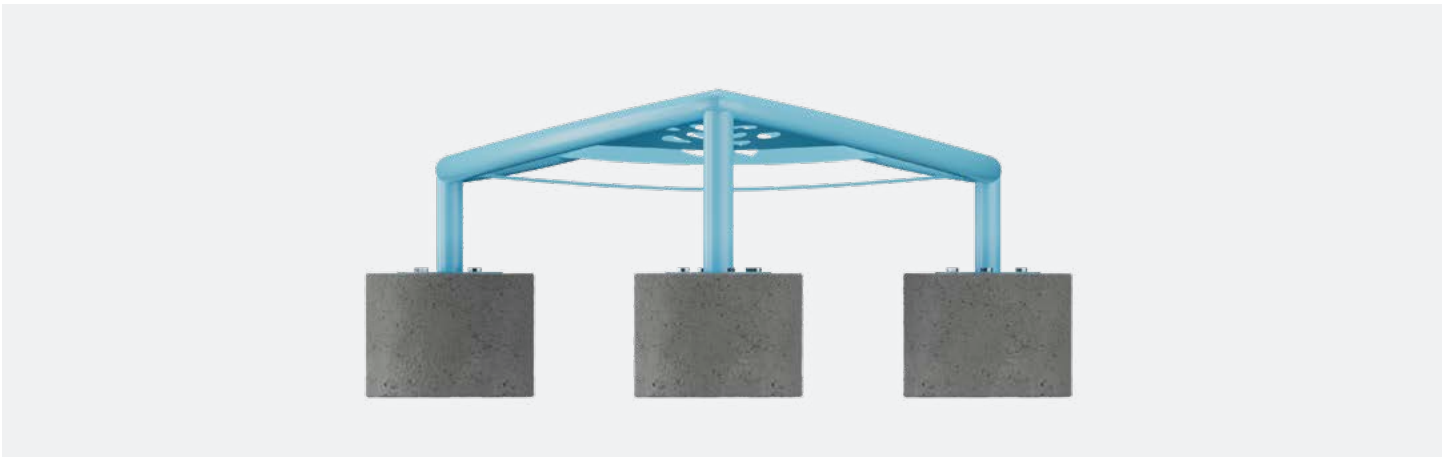

Riverbed Crossing - Precedent



The Philadelphia School



FDR Park

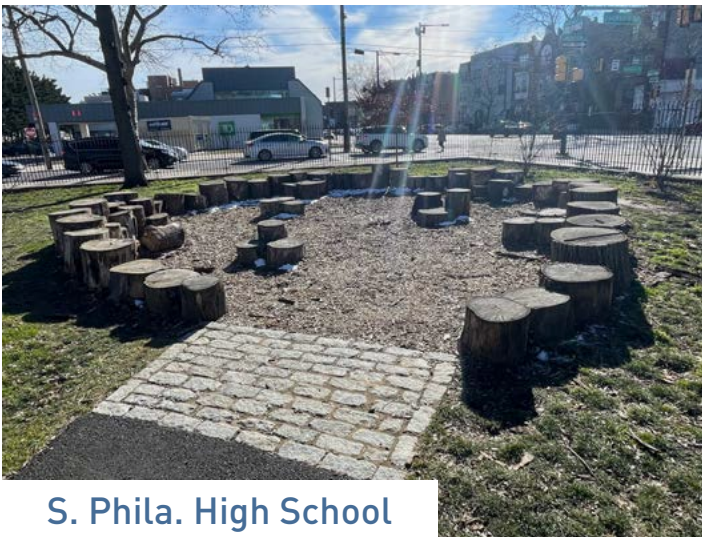

S. Phila. High School



S. Phila. High School

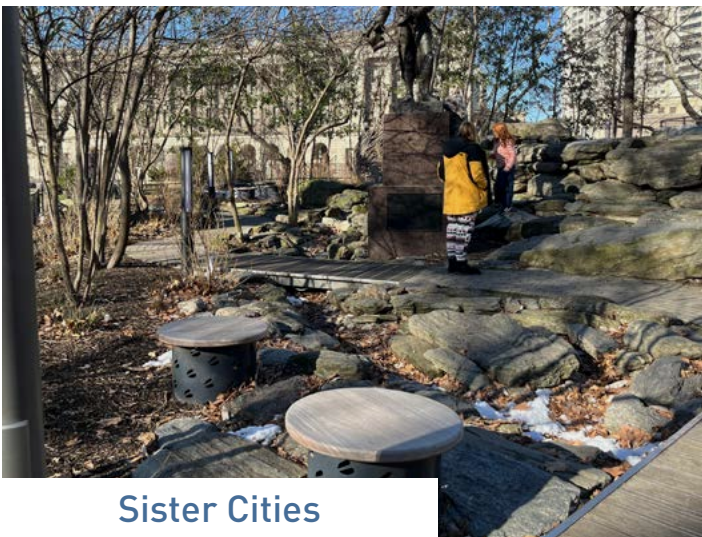

Sister Cities



Winter Street Greenway

Riverbed Crossing - Technical Drawings Overall Layout

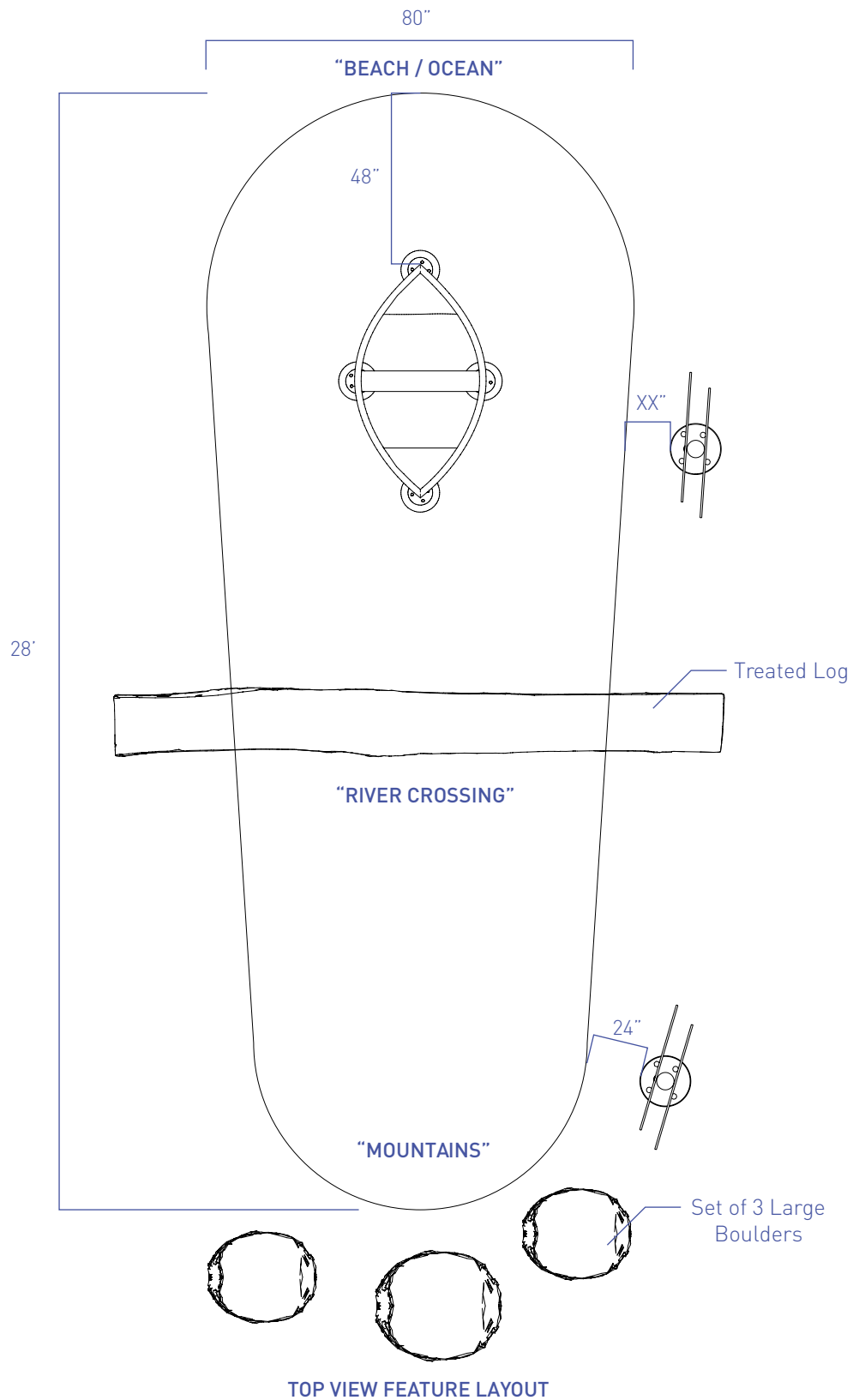

Riverbed Crossing - Technical Drawings Play Boat

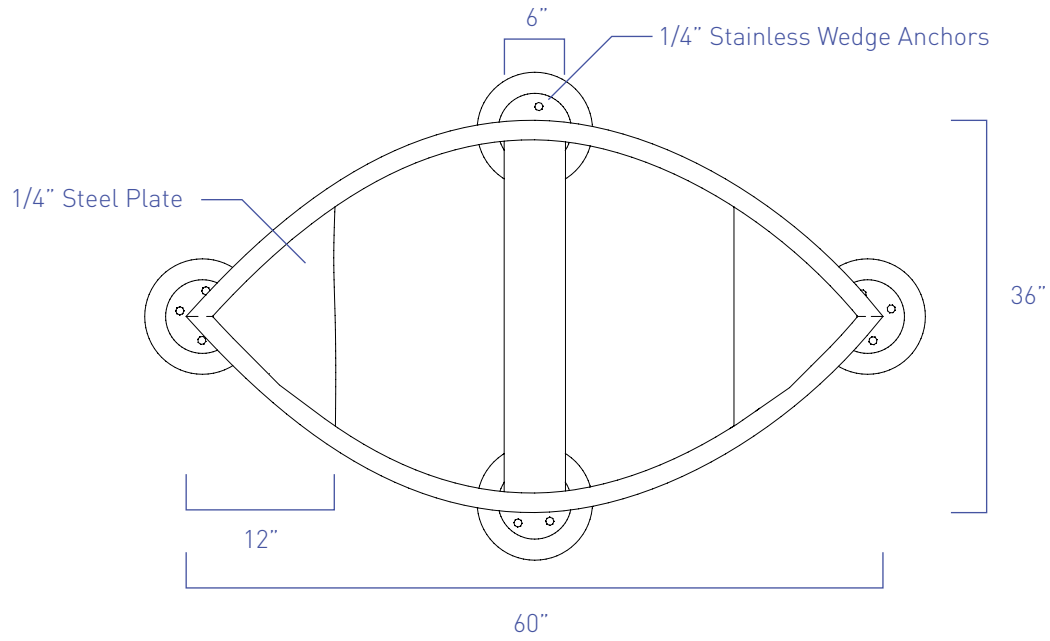

TOP VIEW

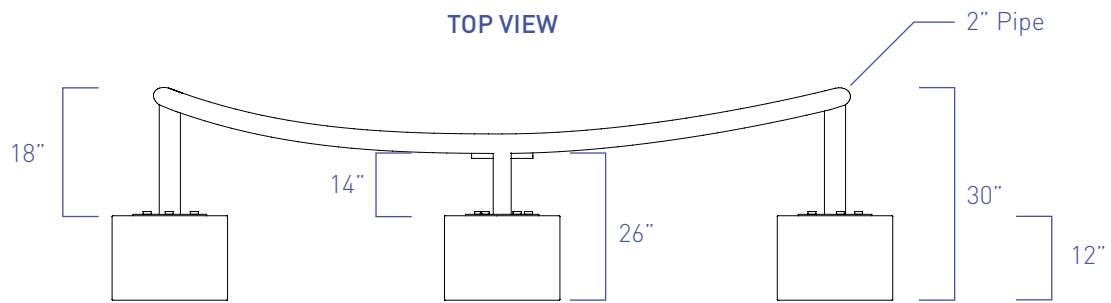

SIDE VIEW

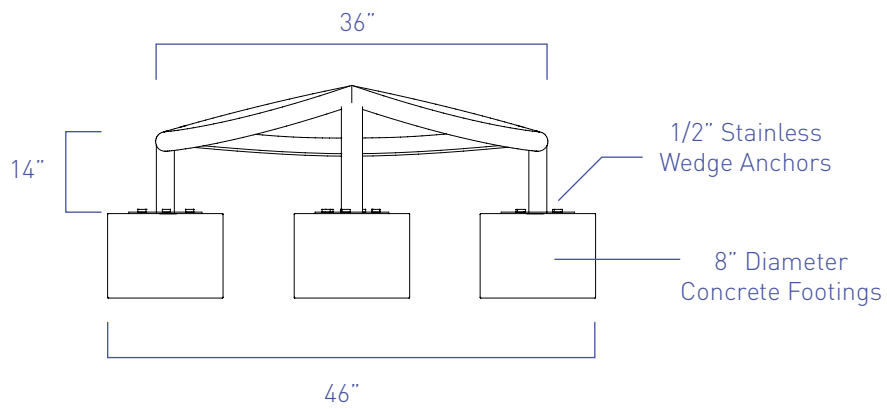

FRONT VIEW

Riverbed Crossing - Proposed Installation Method

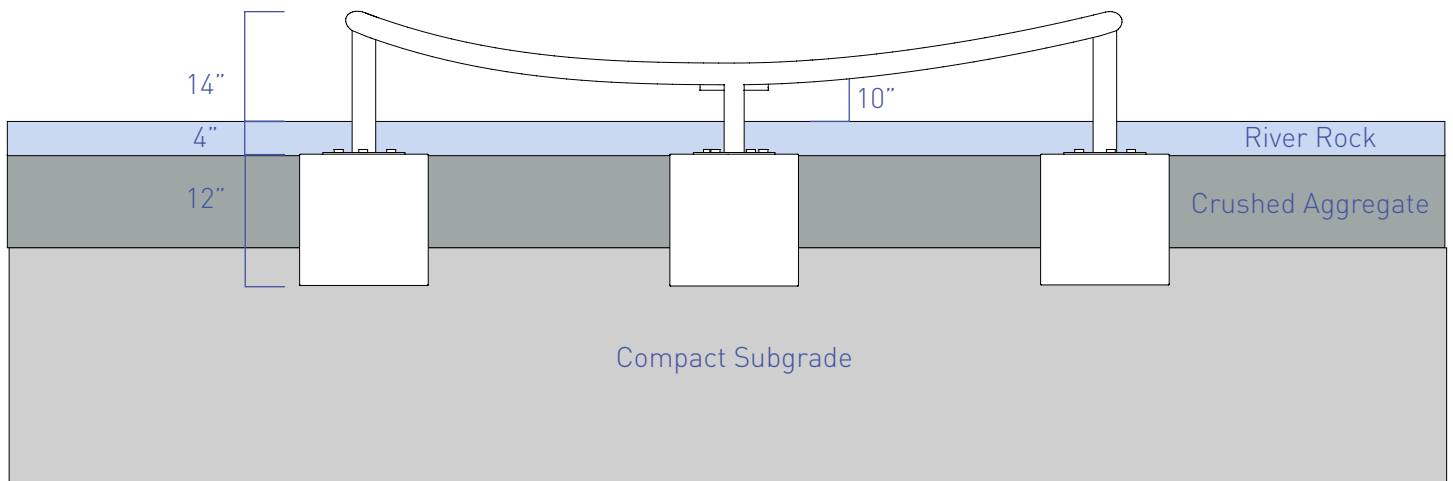

ZigZag Beams - Balancing Mind & Body

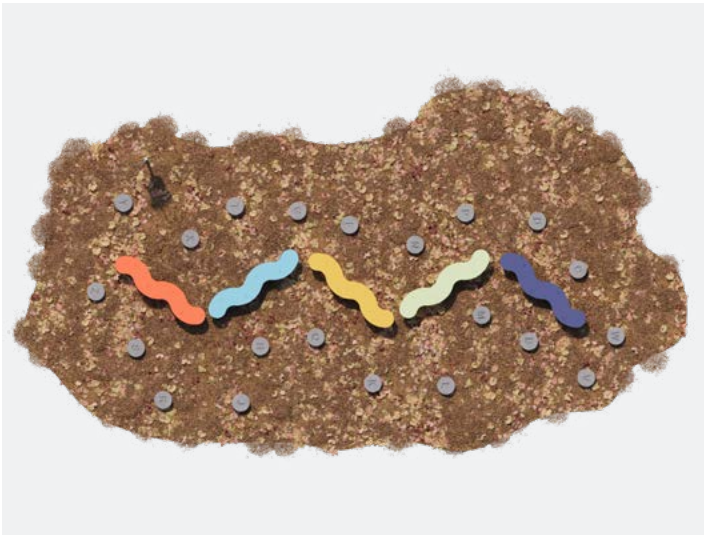

ZigZag Beams - Precedent



Seger Playground



Frankford Friends

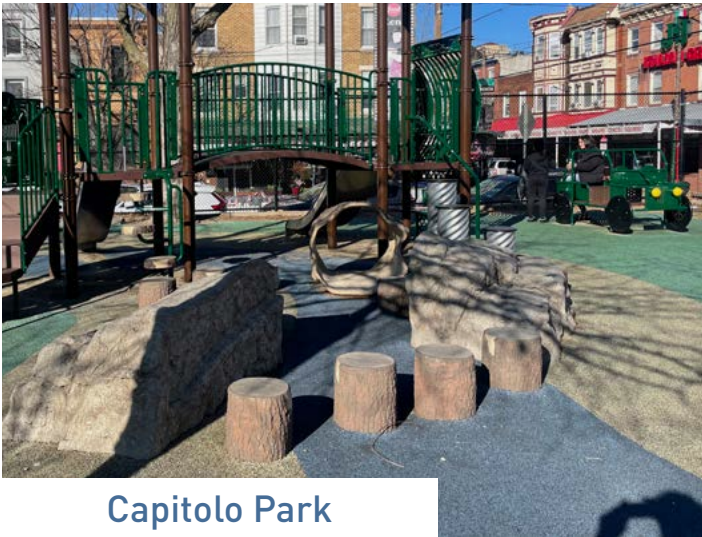

Capitolo Park



E. Penitentiary P.G.



Awbury Arboretum



FDR Park

ZigZag Beams - Component Detail

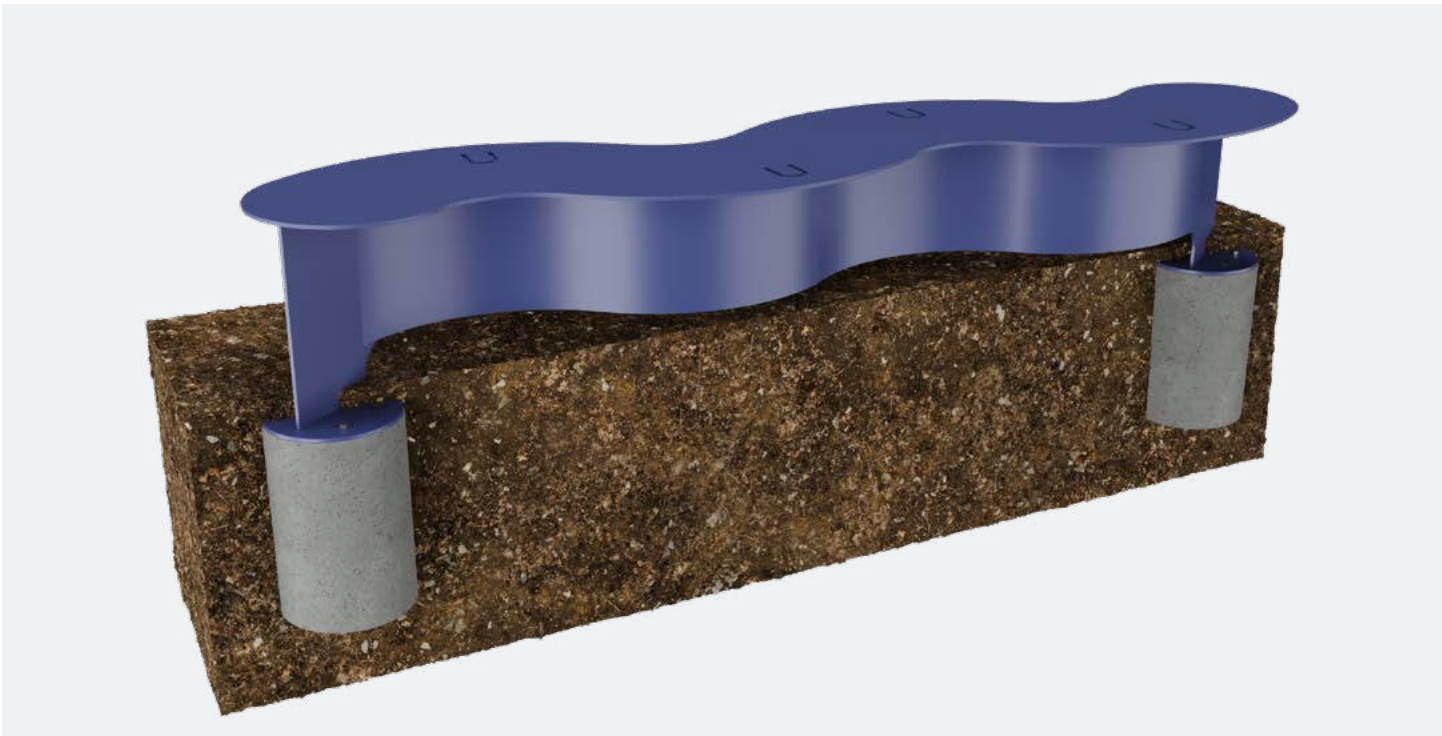
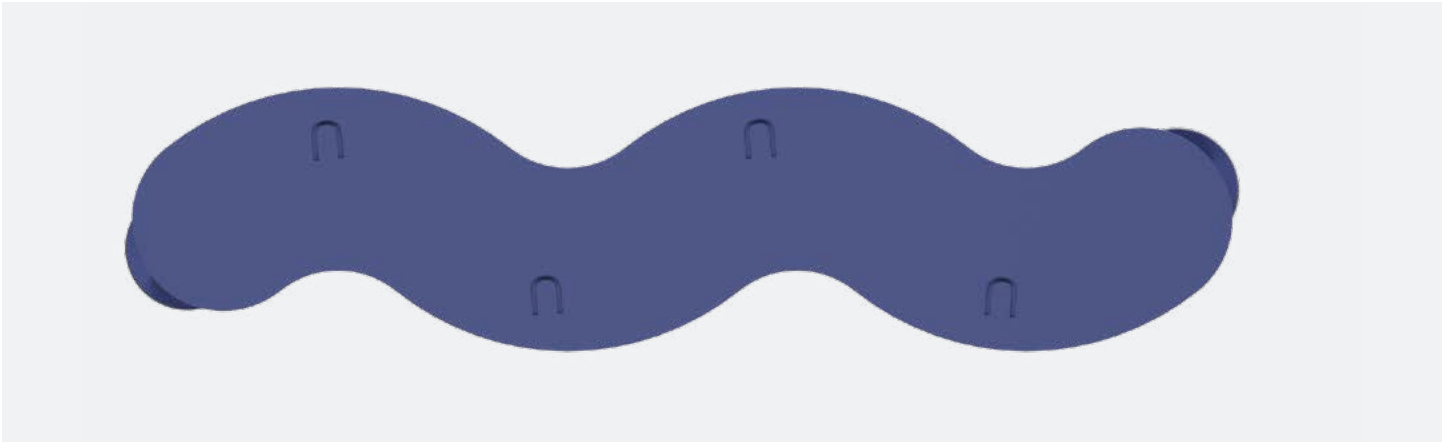

ZigZag Beams - Technical Drawings Overall Layout

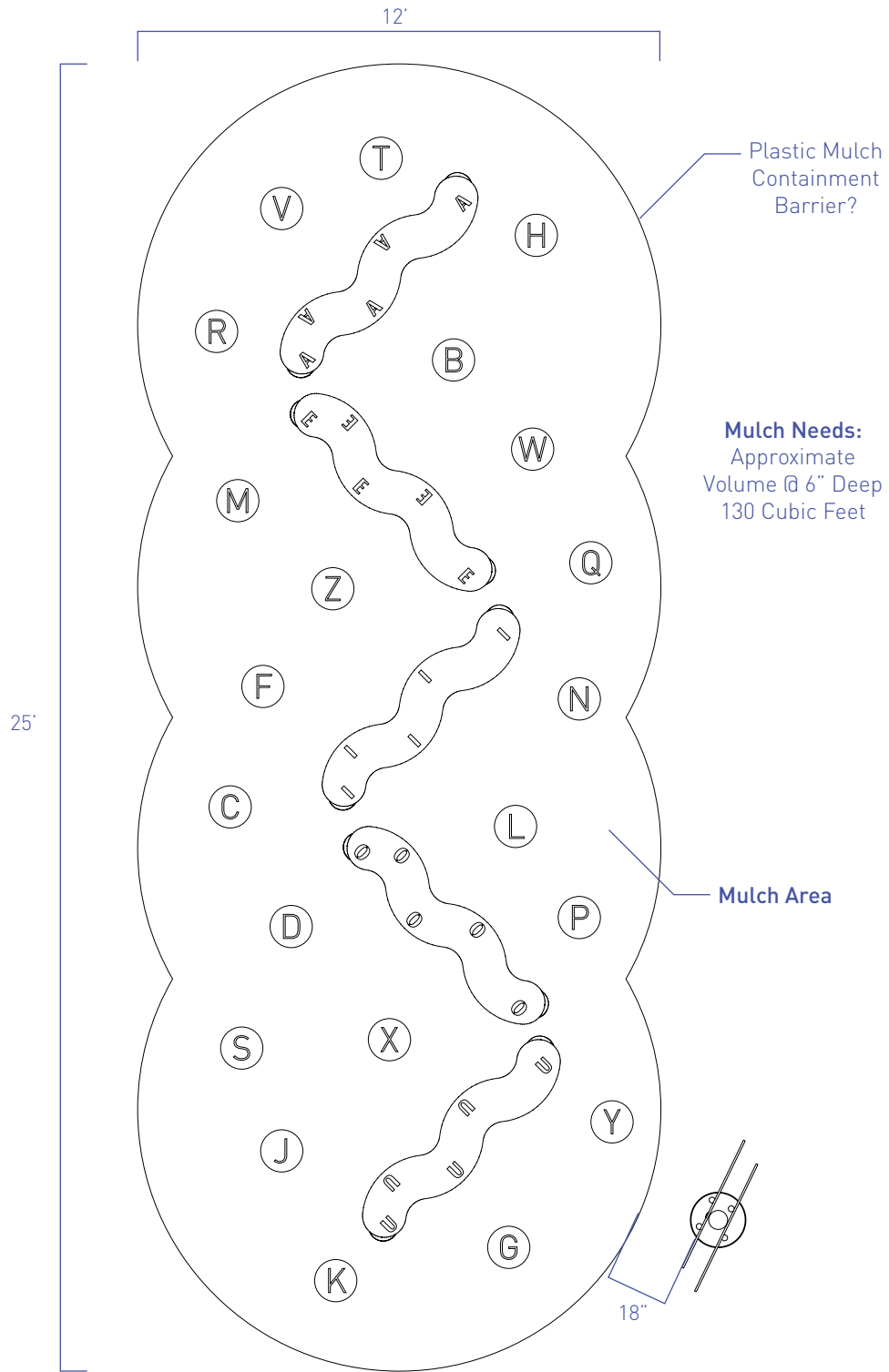

TOP VIEW FEATURE LAYOUT

ZigZag Beams - Technical Drawings

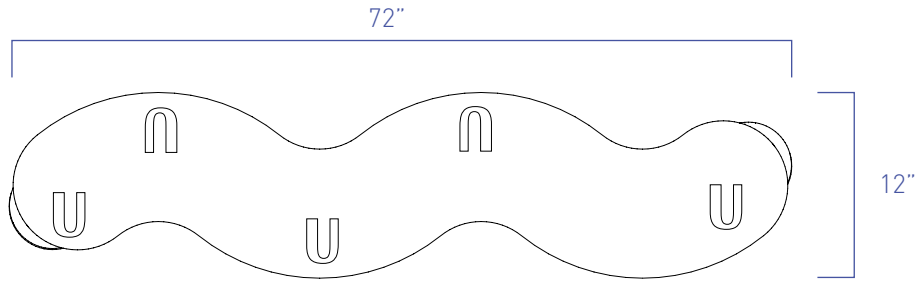

TOP VIEW



SIDE VIEW

CONSONANTS

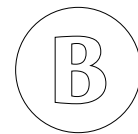

TOP VIEW

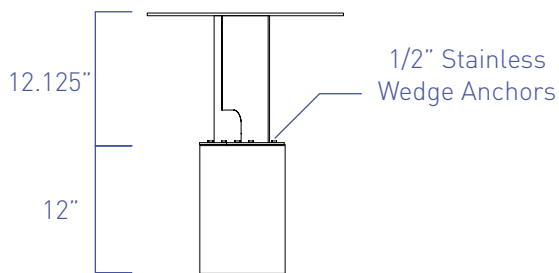

FRONT VIEW

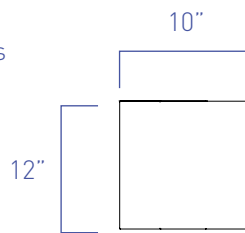

FRONT VIEW

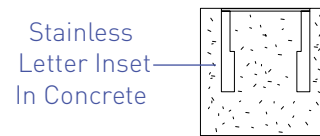

CROSS SECTION

ZigZag Beams - Proposed Installation Method

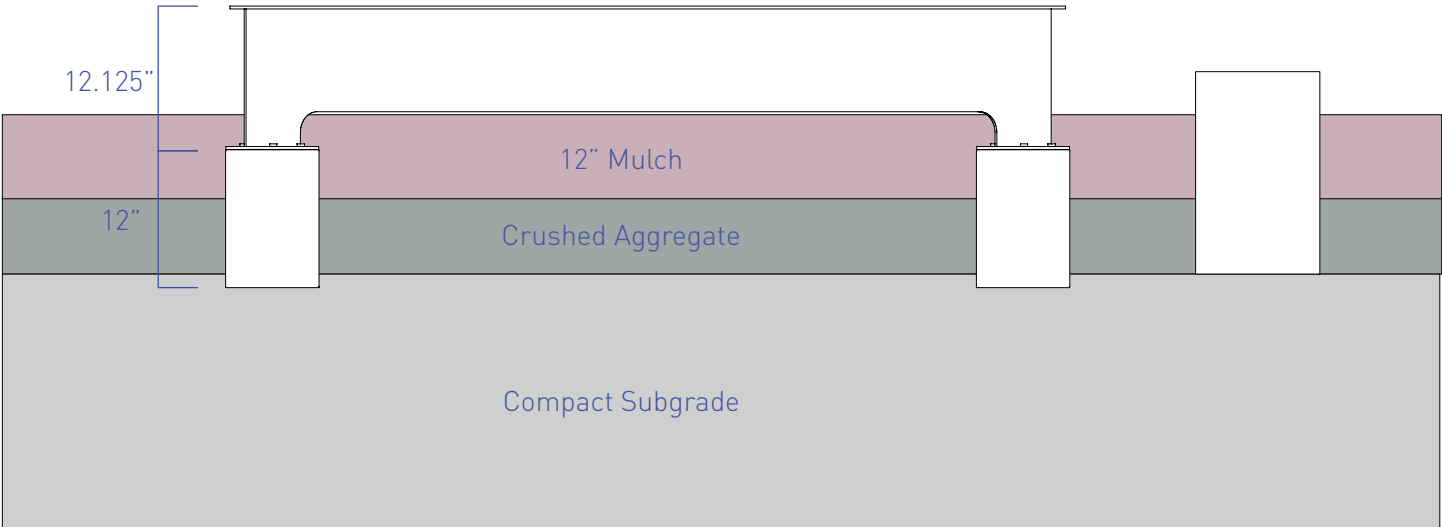

Play Village - Imaginary Play

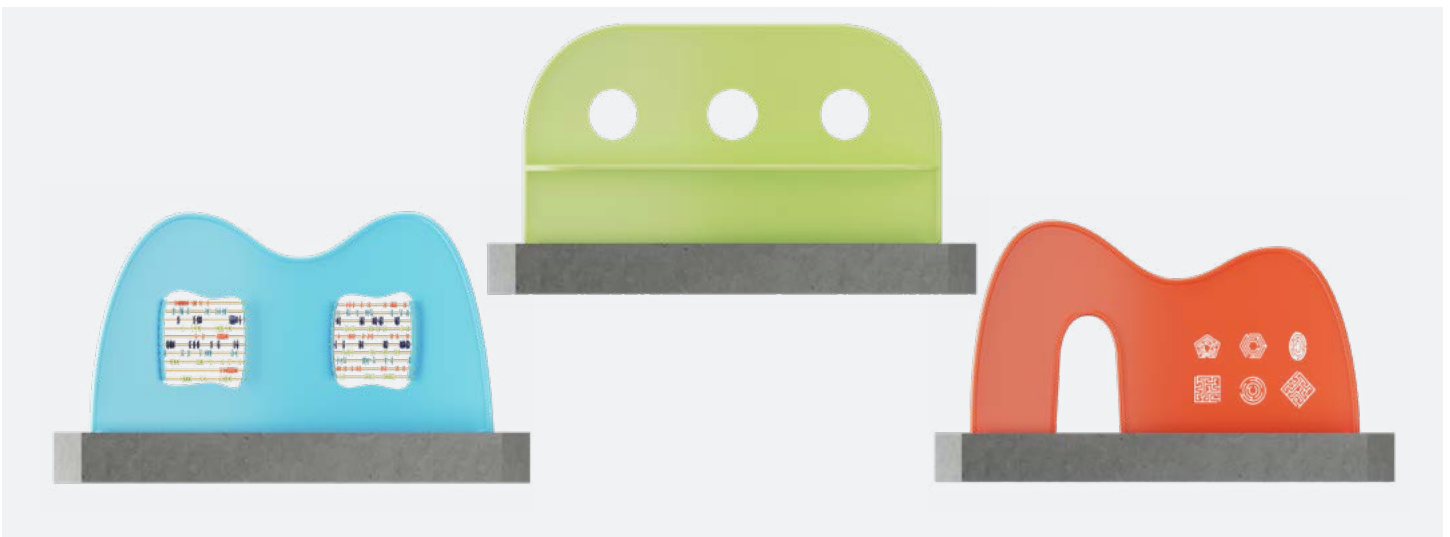

Play Village - Abacus Station Detail



Play Village - Tactile Maze Detail



Play Village - Windows Detail



Play Village - Precedent



FDR Park



Hancock Playground



Northwood Park



Piedmont Park Atlanta



Helen Diller San Fran



Urban Conga Cleveland

Play Village - Technical Drawings Overall Layout

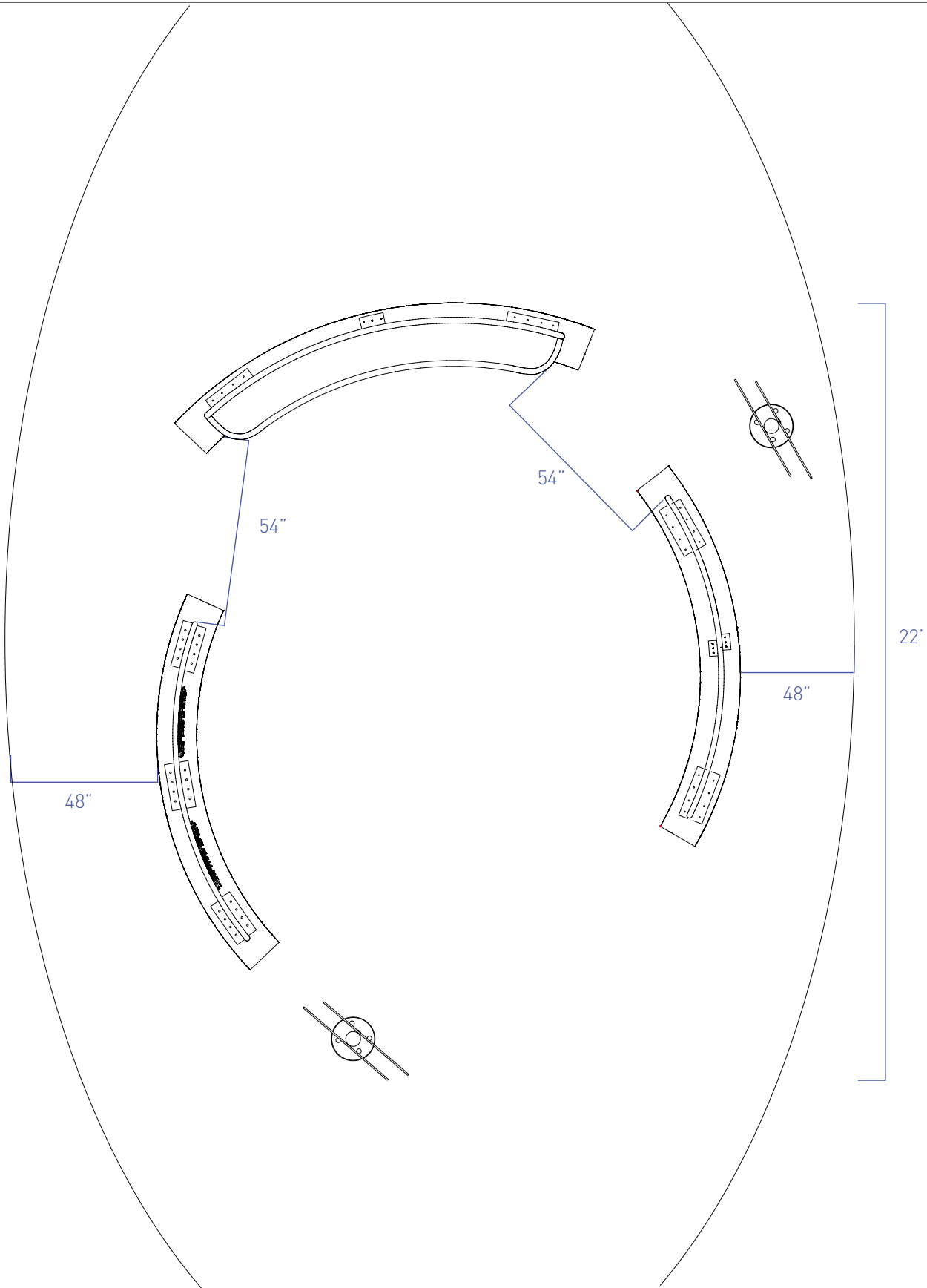

Play Village - Technical Drawings Tactile Maze Wall

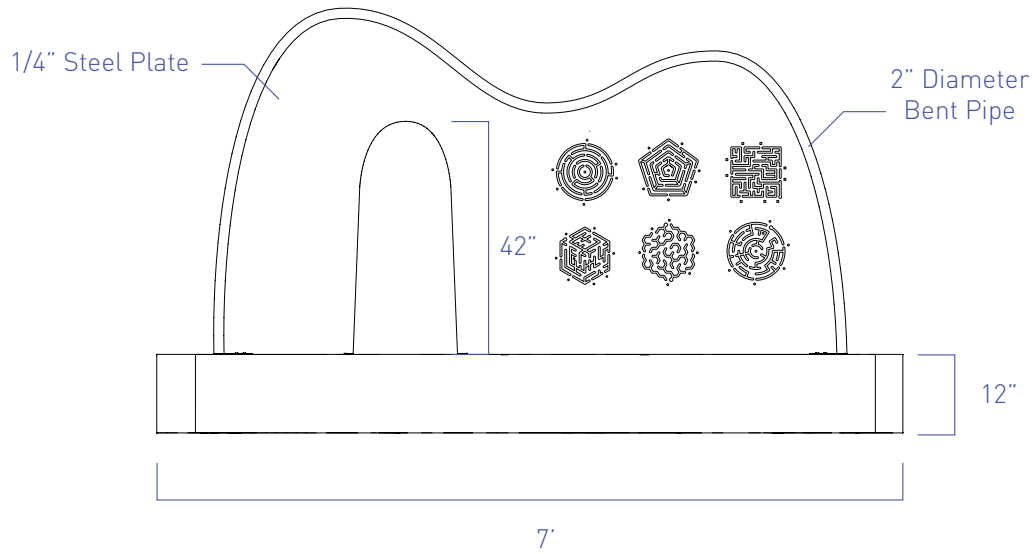

FRONT VIEW

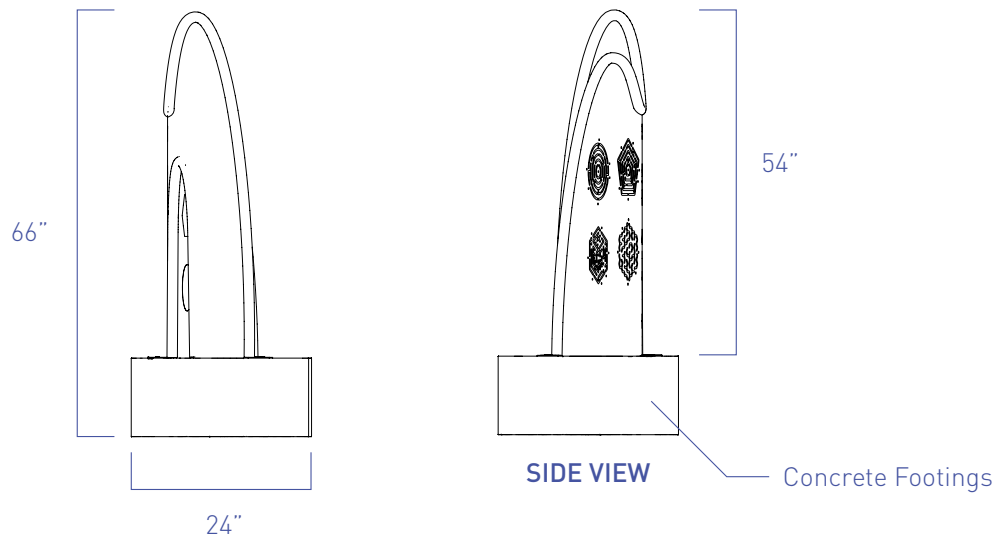

SIDE VIEW

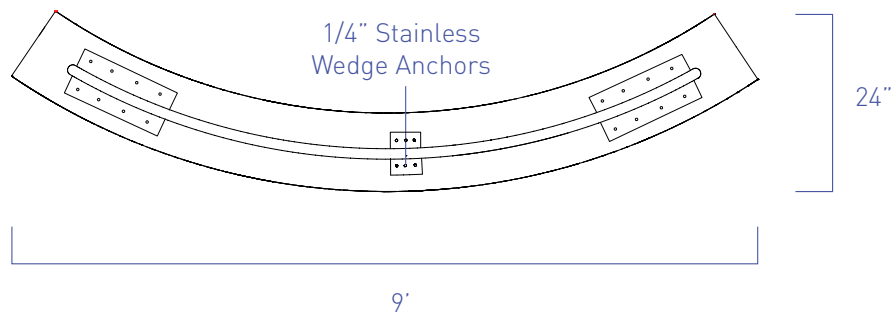

TOP VIEW

Play Village - Technical Drawings Tactile Maze Wall Detail

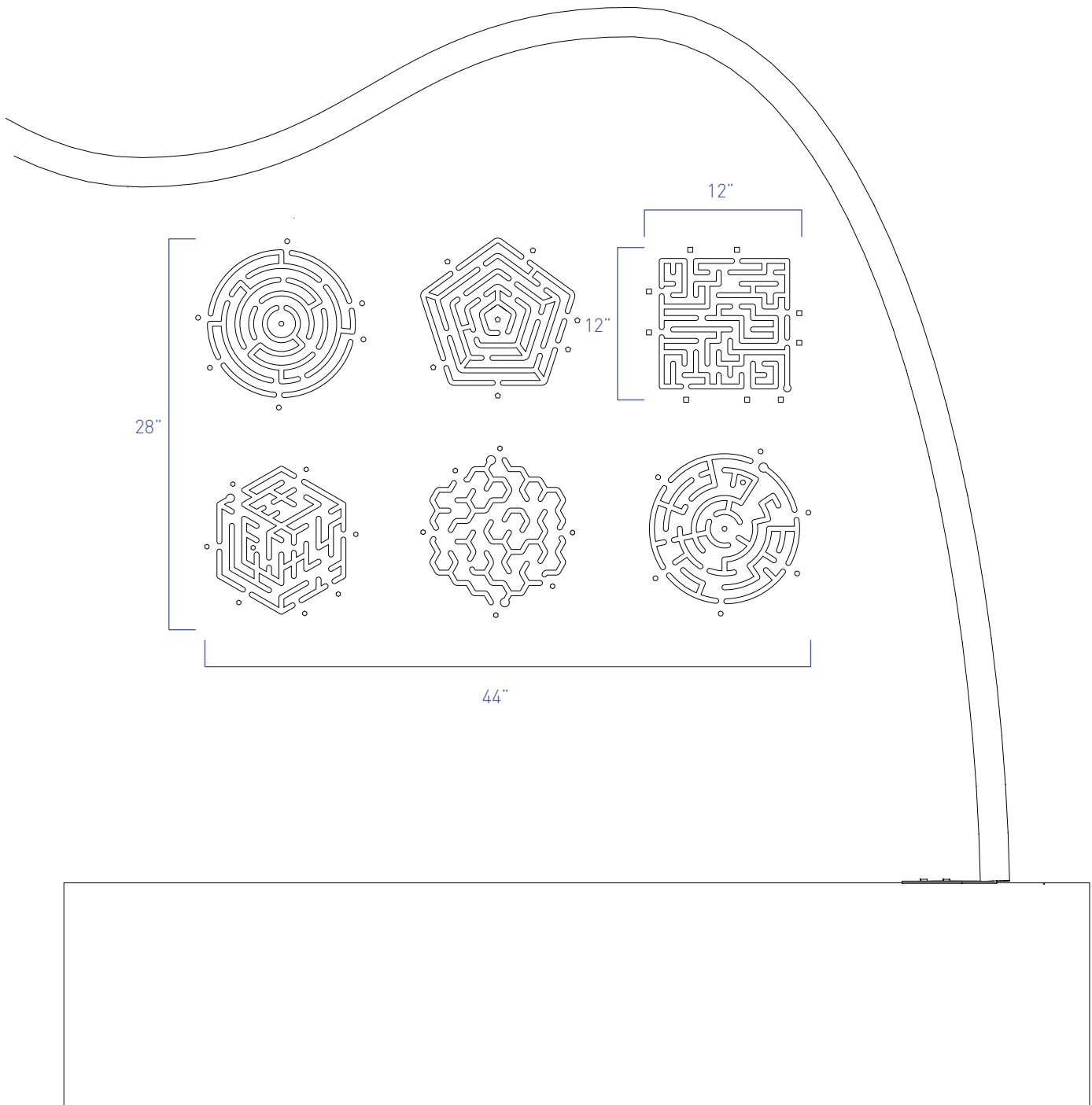

Play Village - Technical Drawings Abacus Wall

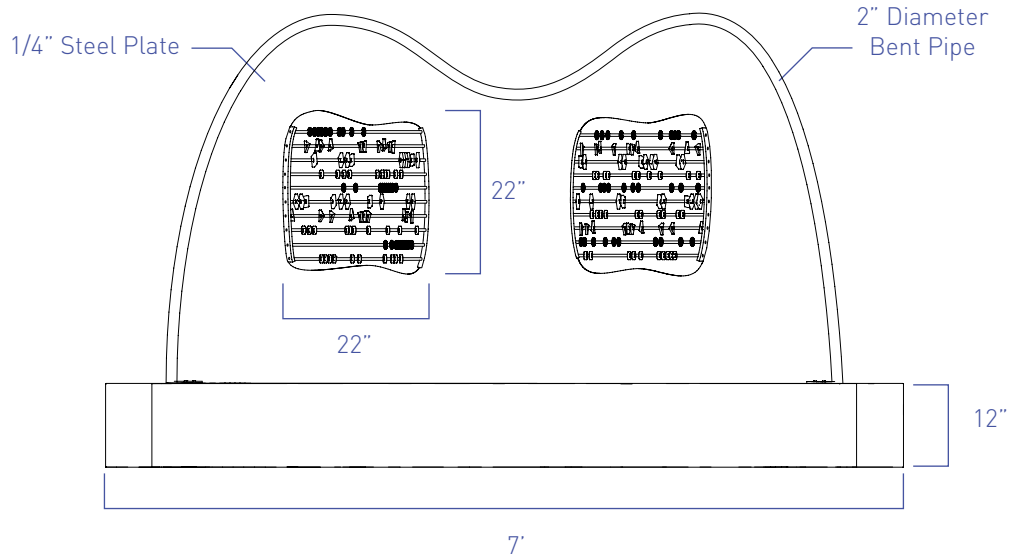

FRONT VIEW

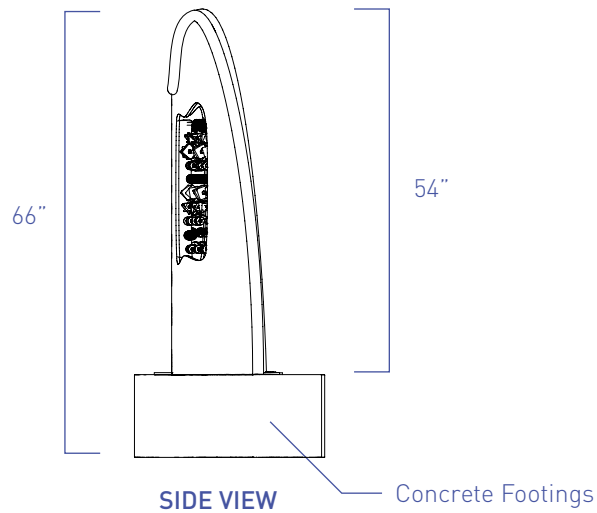

SIDE VIEW

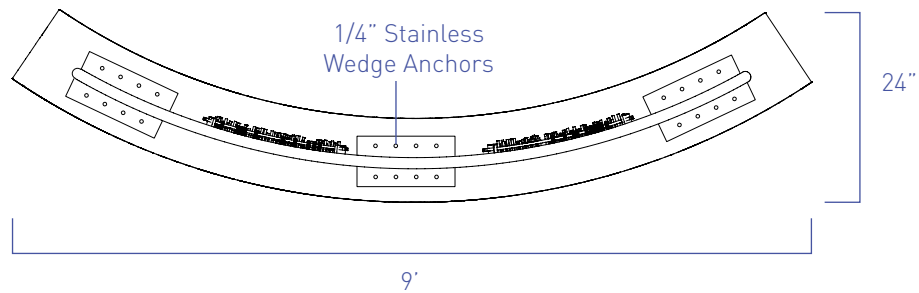

TOP VIEW

Play Village - Technical Drawings Abacus Wall Detail

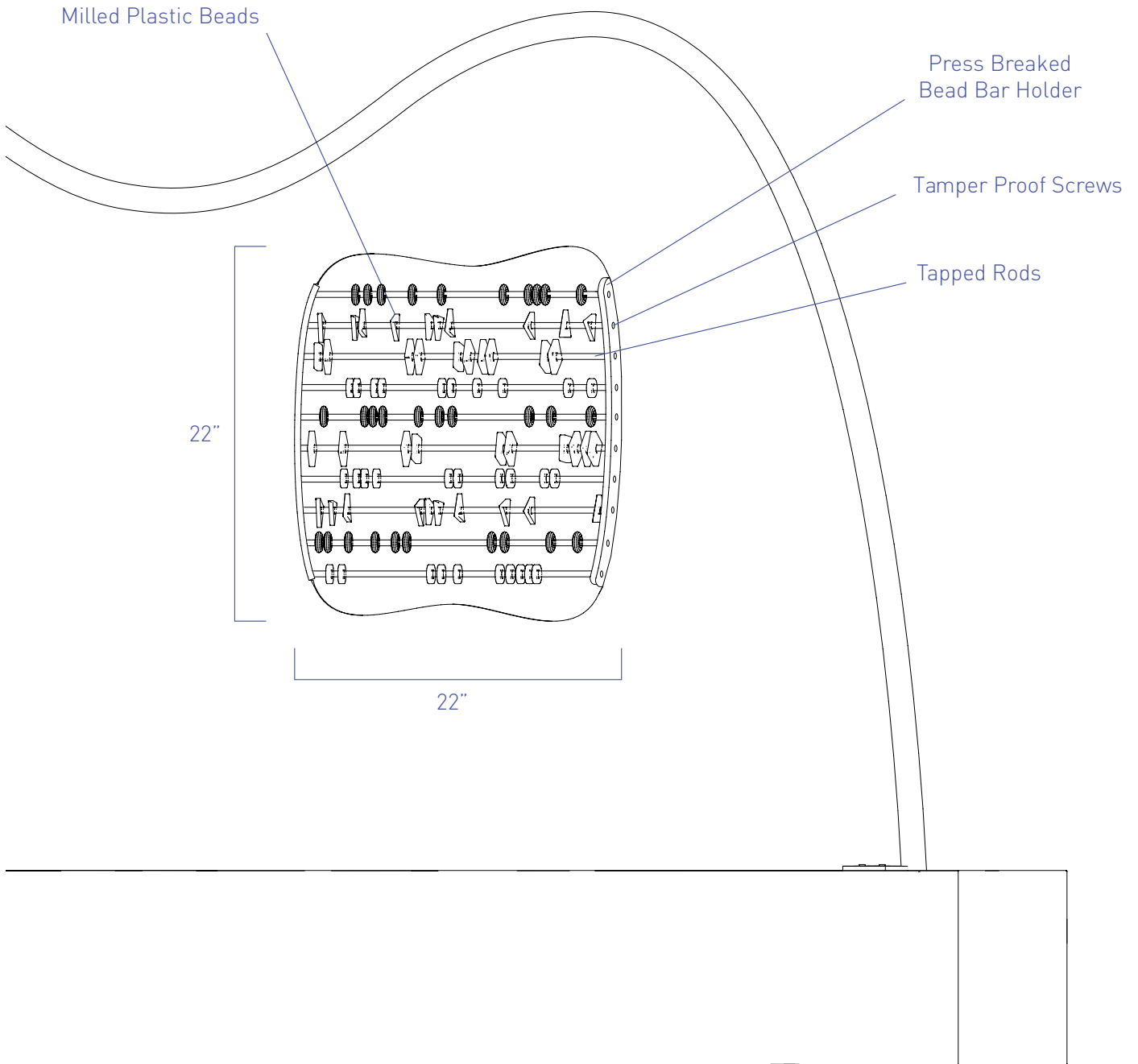

Play Village - Technical Drawings Window Wall

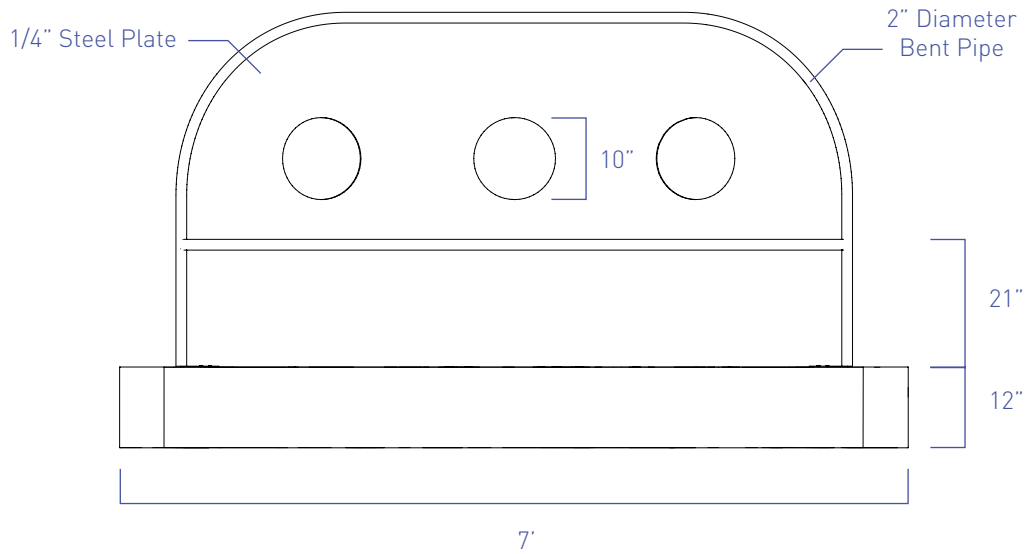

FRONT VIEW

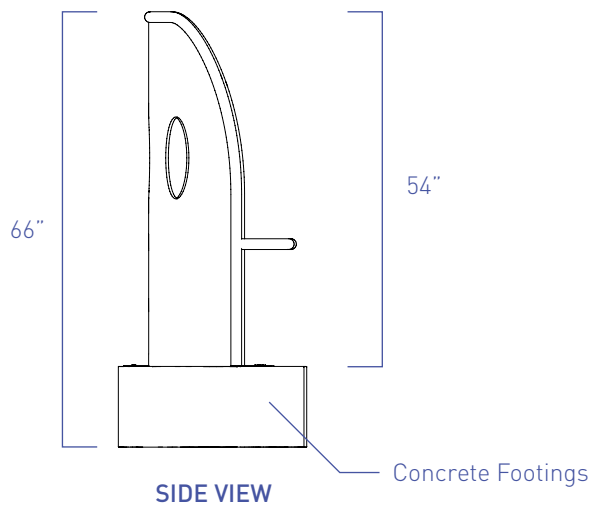

SIDE VIEW

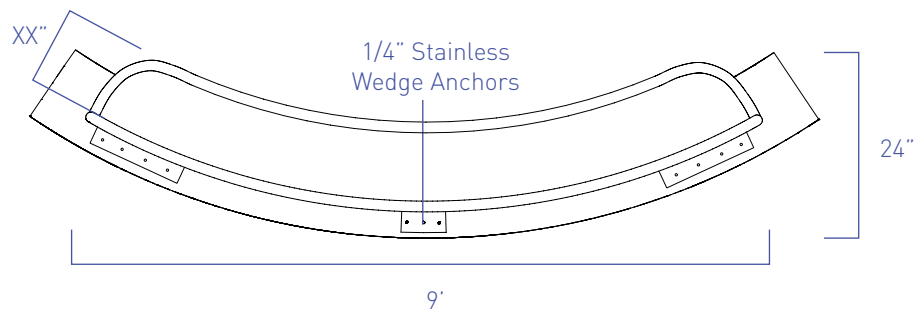

TOP VIEW

Play Village - Proposed Installation Method

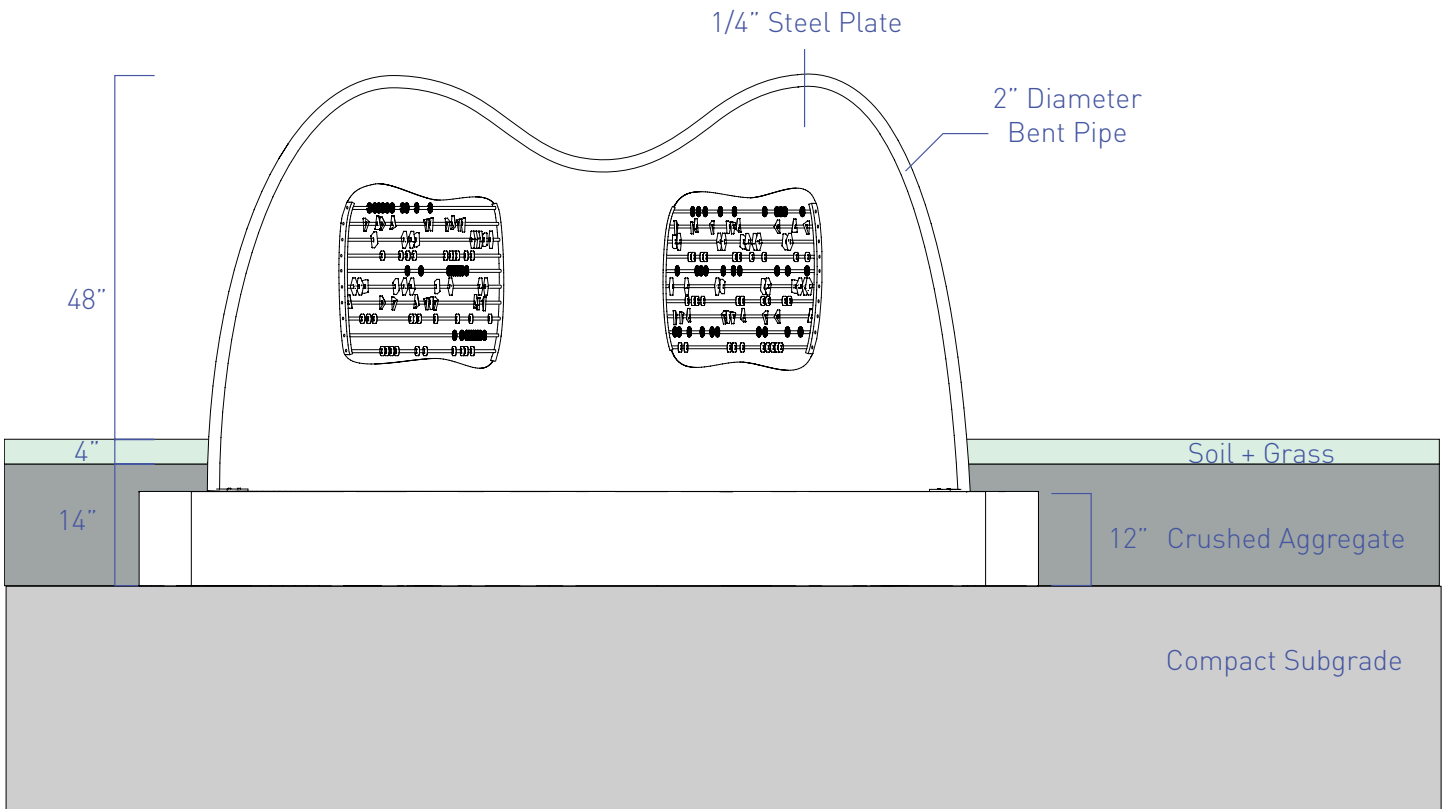
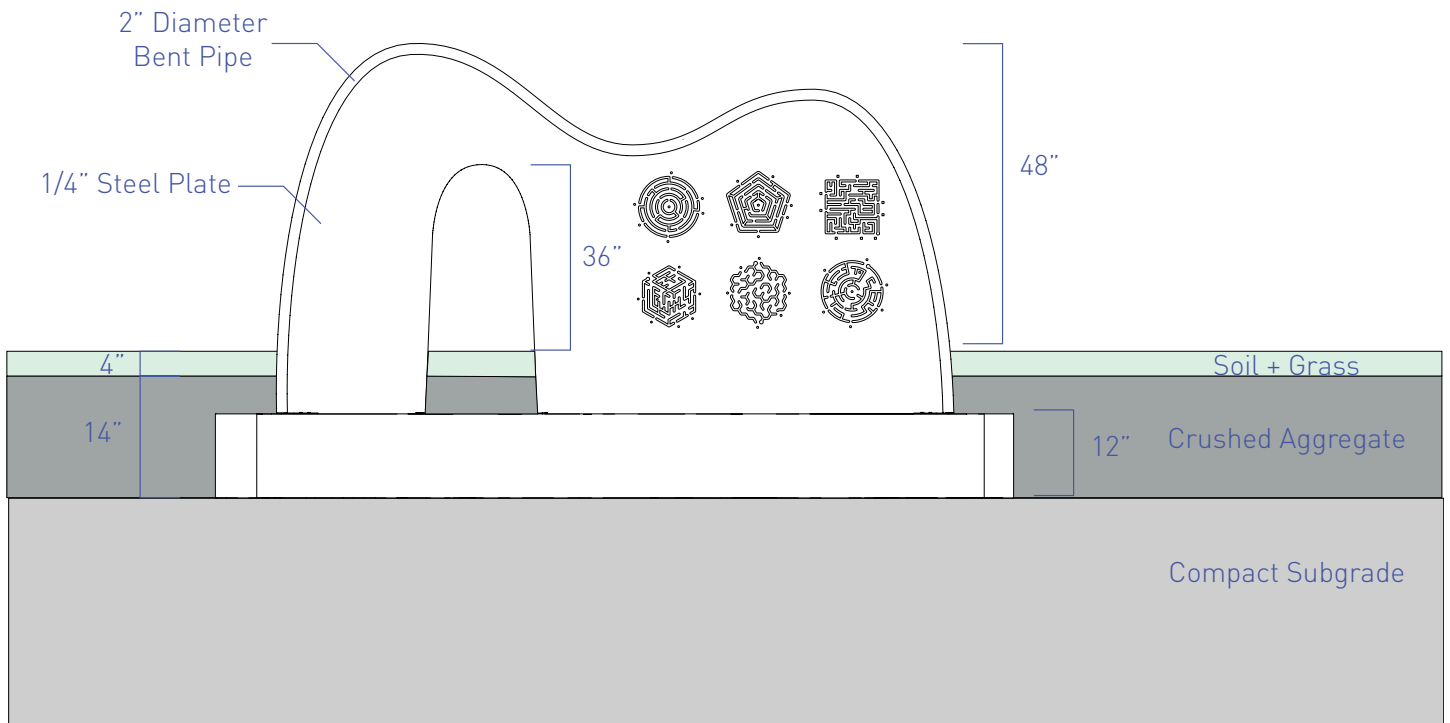

Play Village - Proposed Installation Method

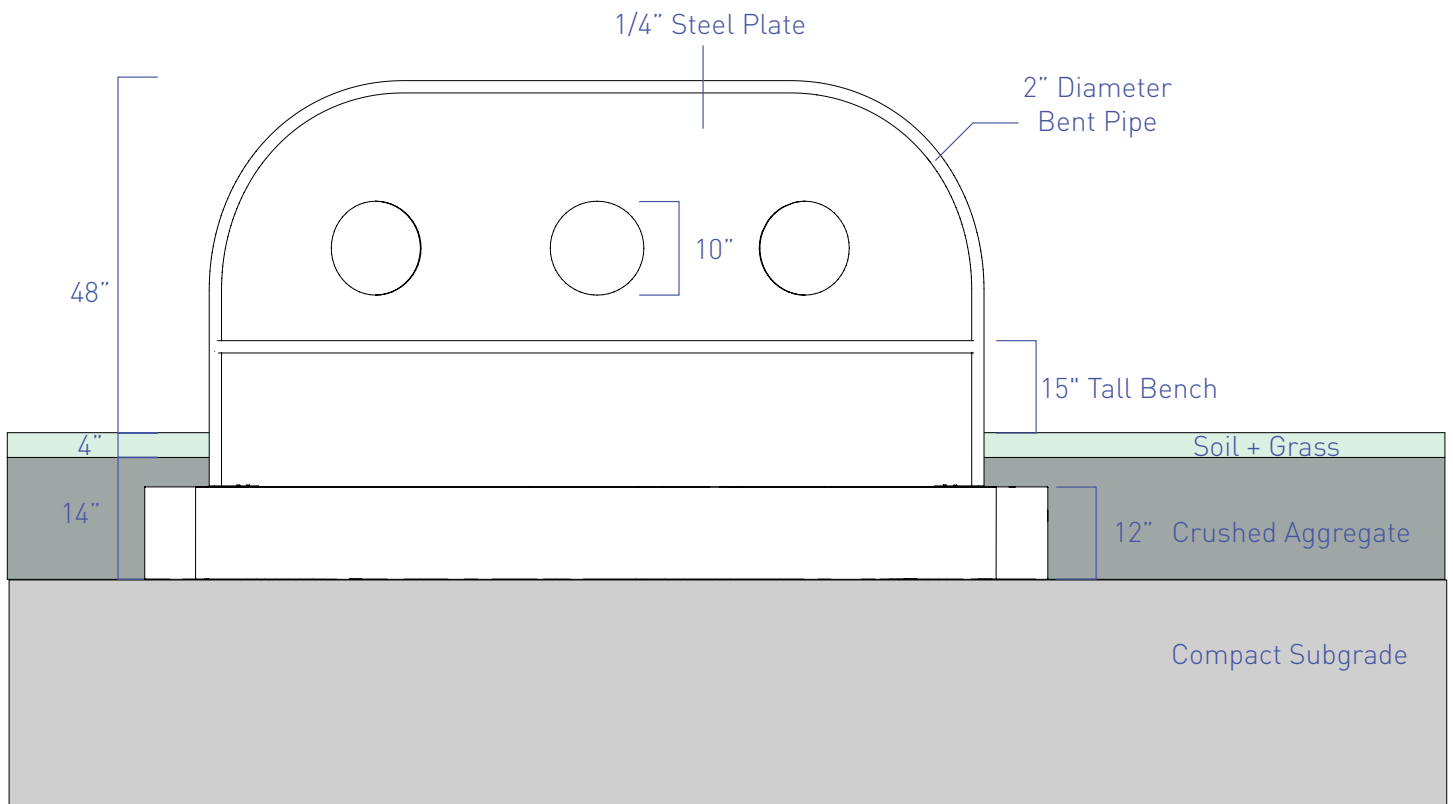

Mounds - Play Hills & Story Game



Mounds - Layout



Mounds - Precedent



Seger Playground



John F. Collins Park



Monet Ave. CA



Fin Project Miami



The Battery NYC



Breakwater Jamestown NY

Mounds - Technical Drawings Overall Layout

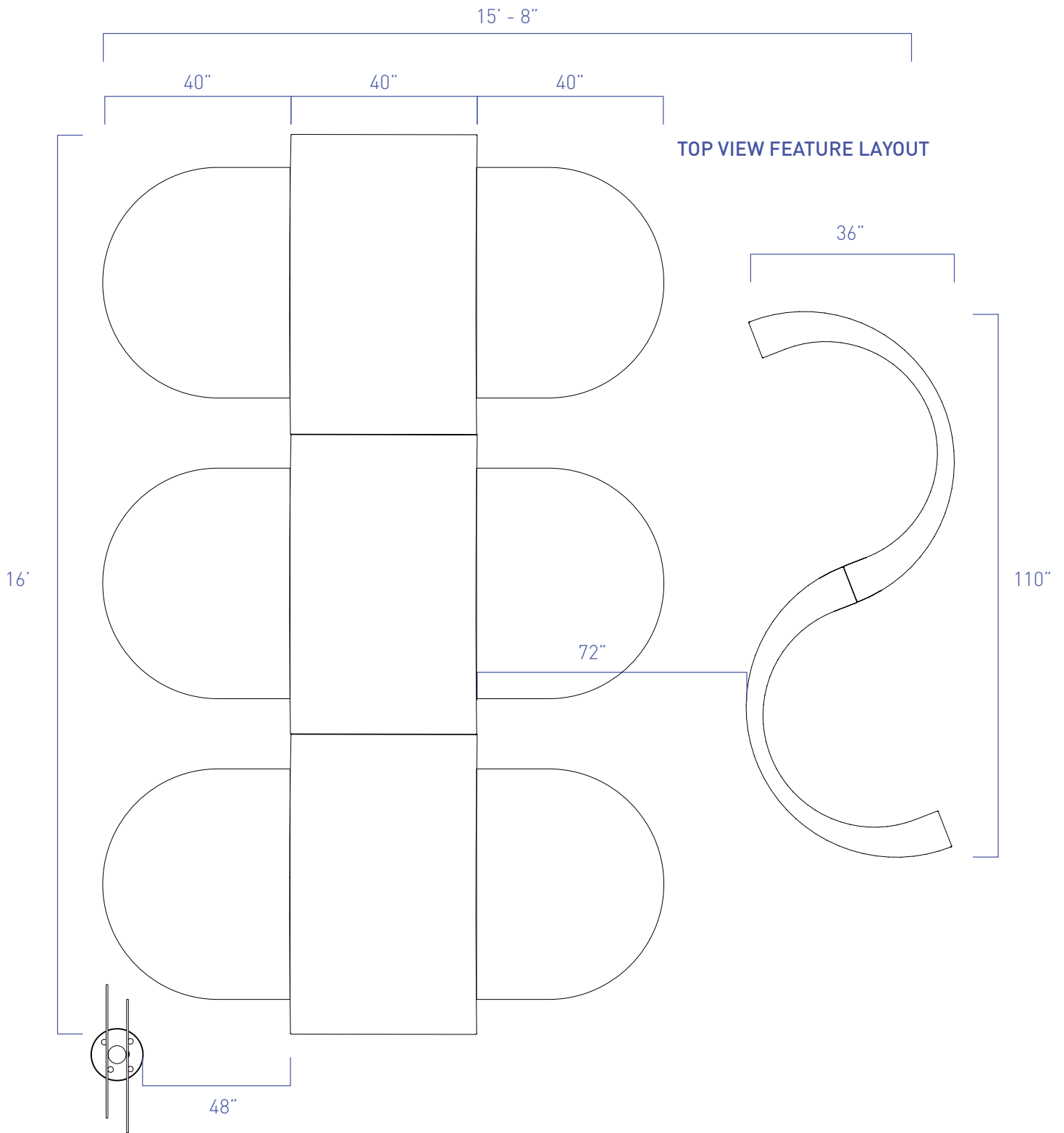

Mounds - Technical Drawings Precast Arches

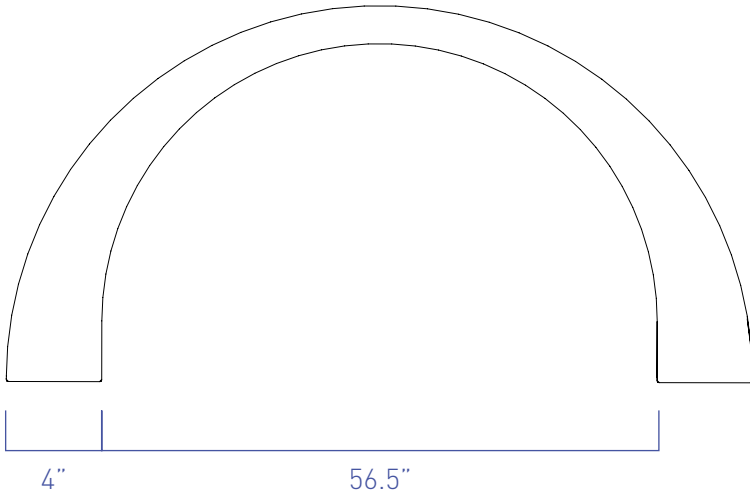

FRONT VIEW

32"



SIDE VIEW

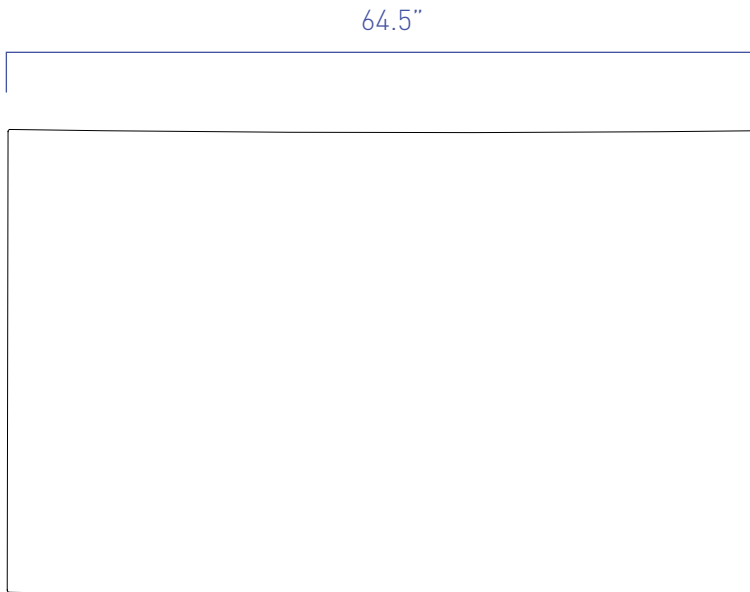

TOP VIEW

Mounds - Proposed Installation Method

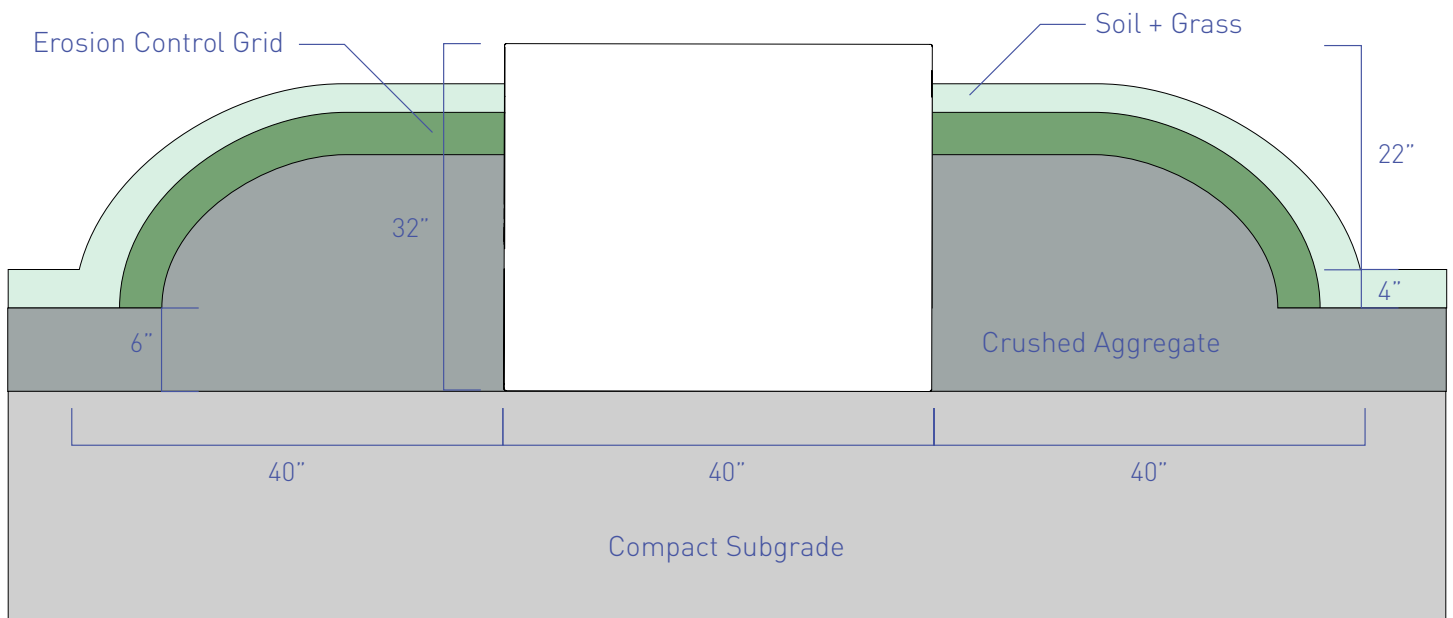

FRONT VIEW

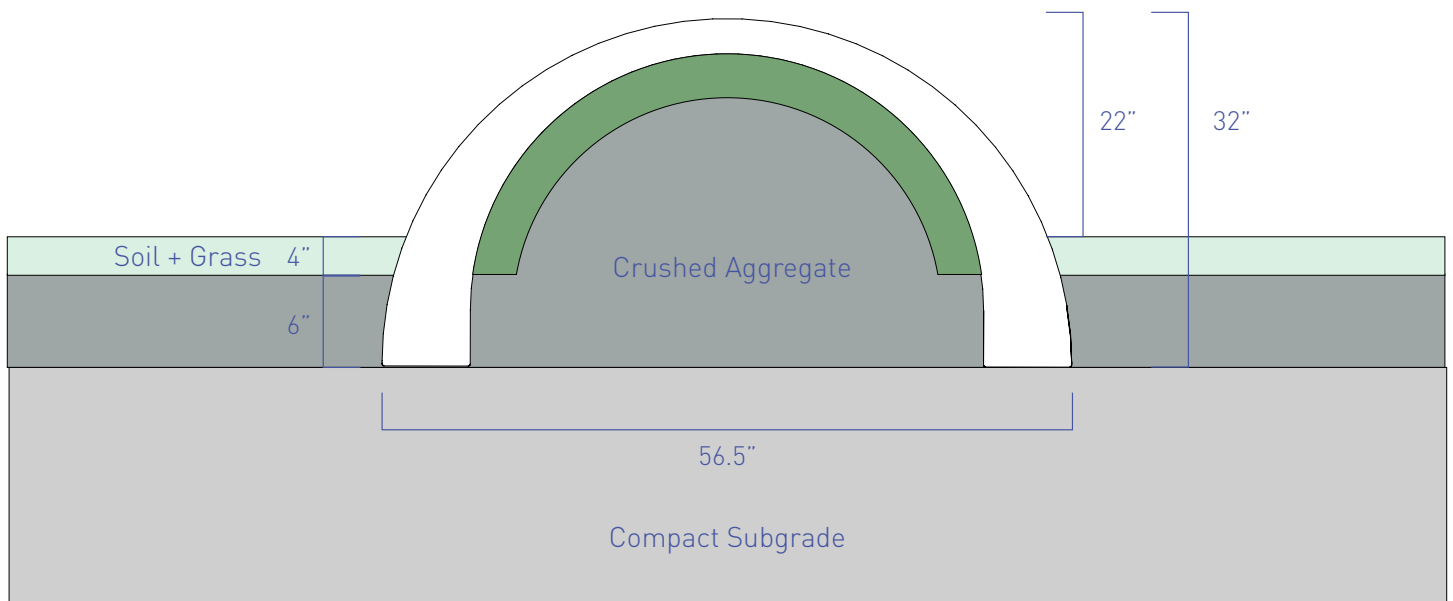

SIDE VIEW

Mounds - Proposed Installation Method

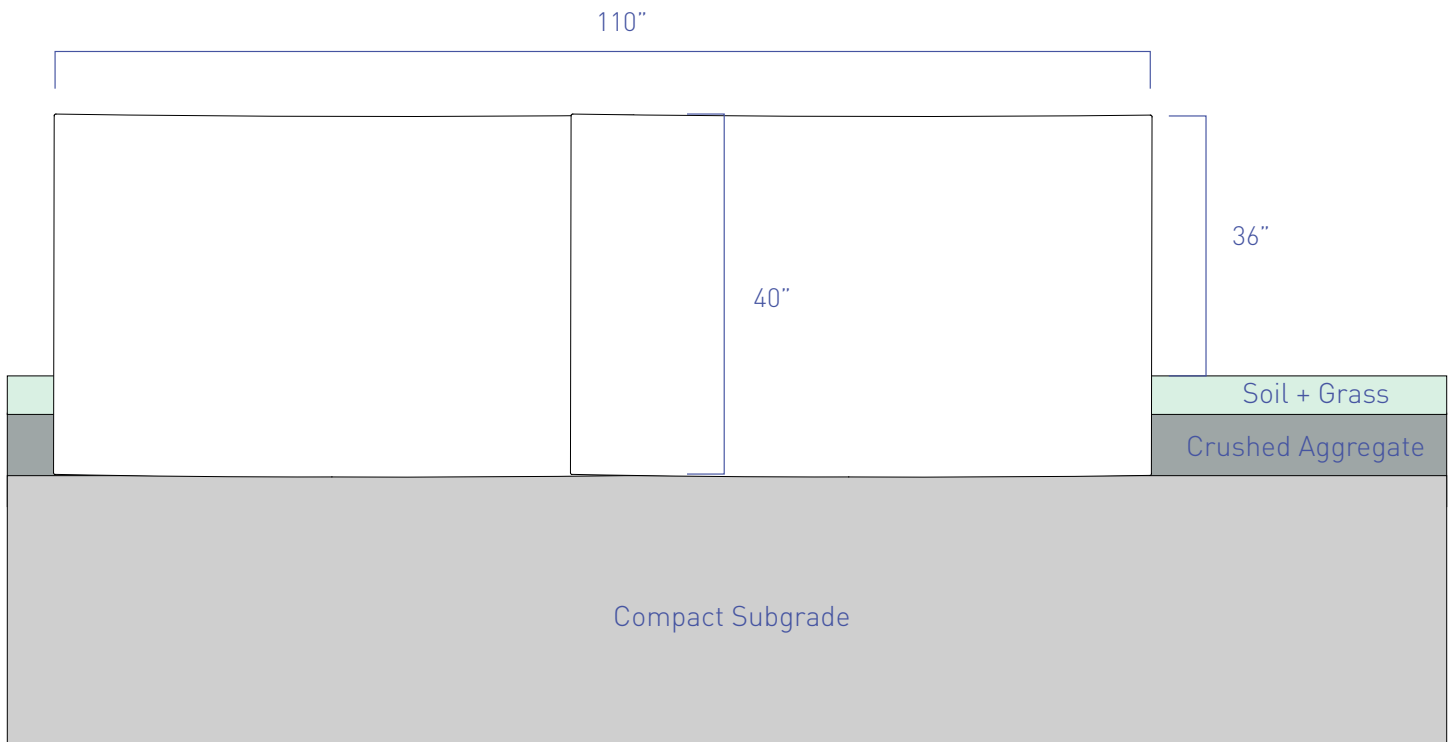

TOP VIEW

Modular Signage - Wayfinding & Education



Seating & Signage - Precedent



Northwood Park



Gold Star Park



FDR Park



E. Penitentiary P.G.



Northwood Park



FDR Park

Modular Signage - Technical Drawing

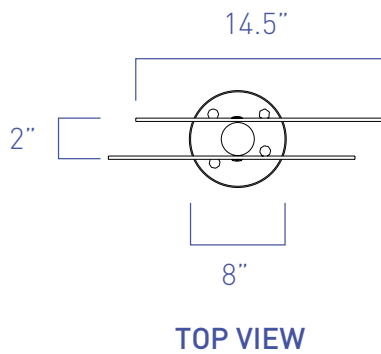
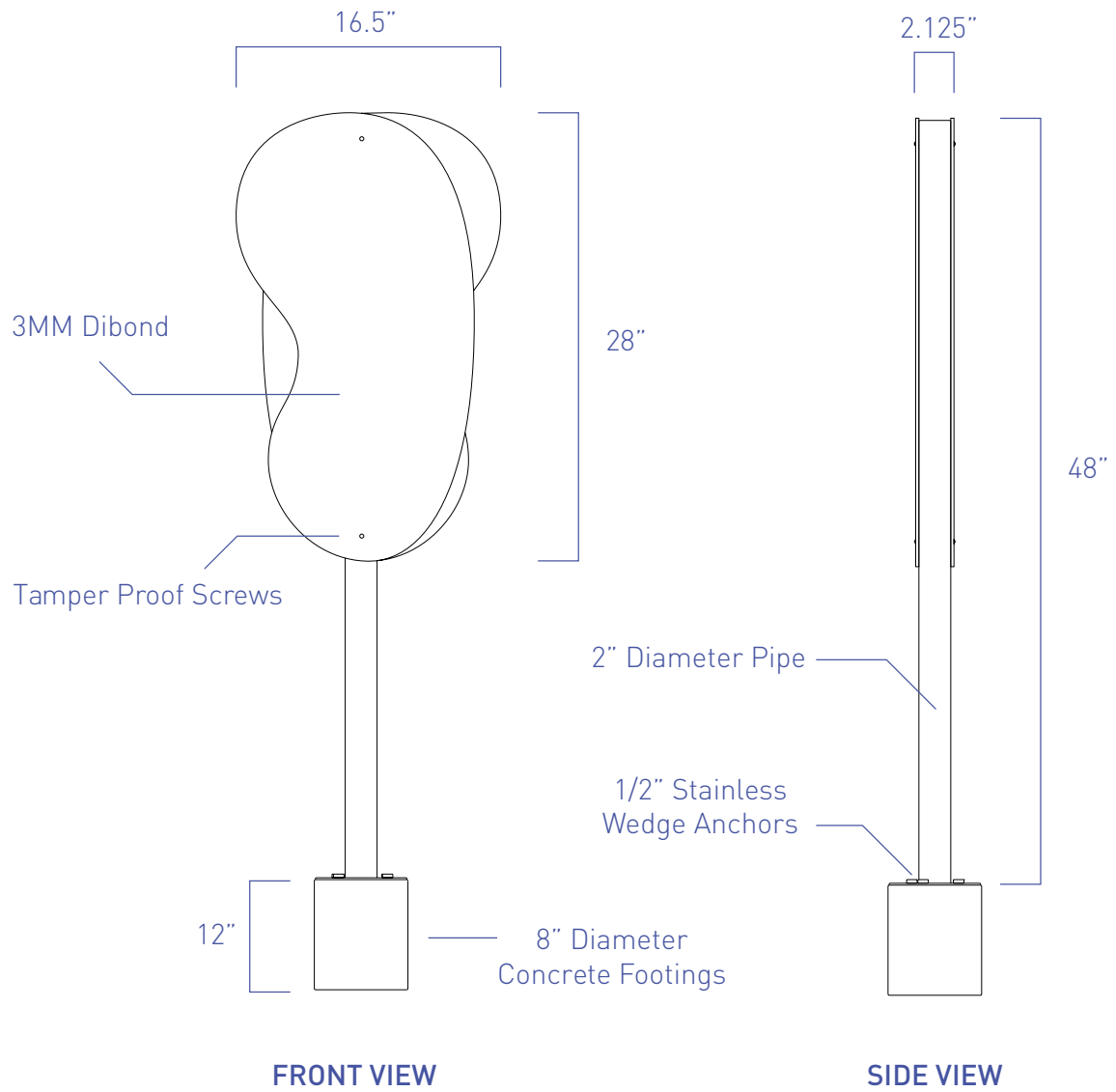

Modular Signage - Proposed Installation Method

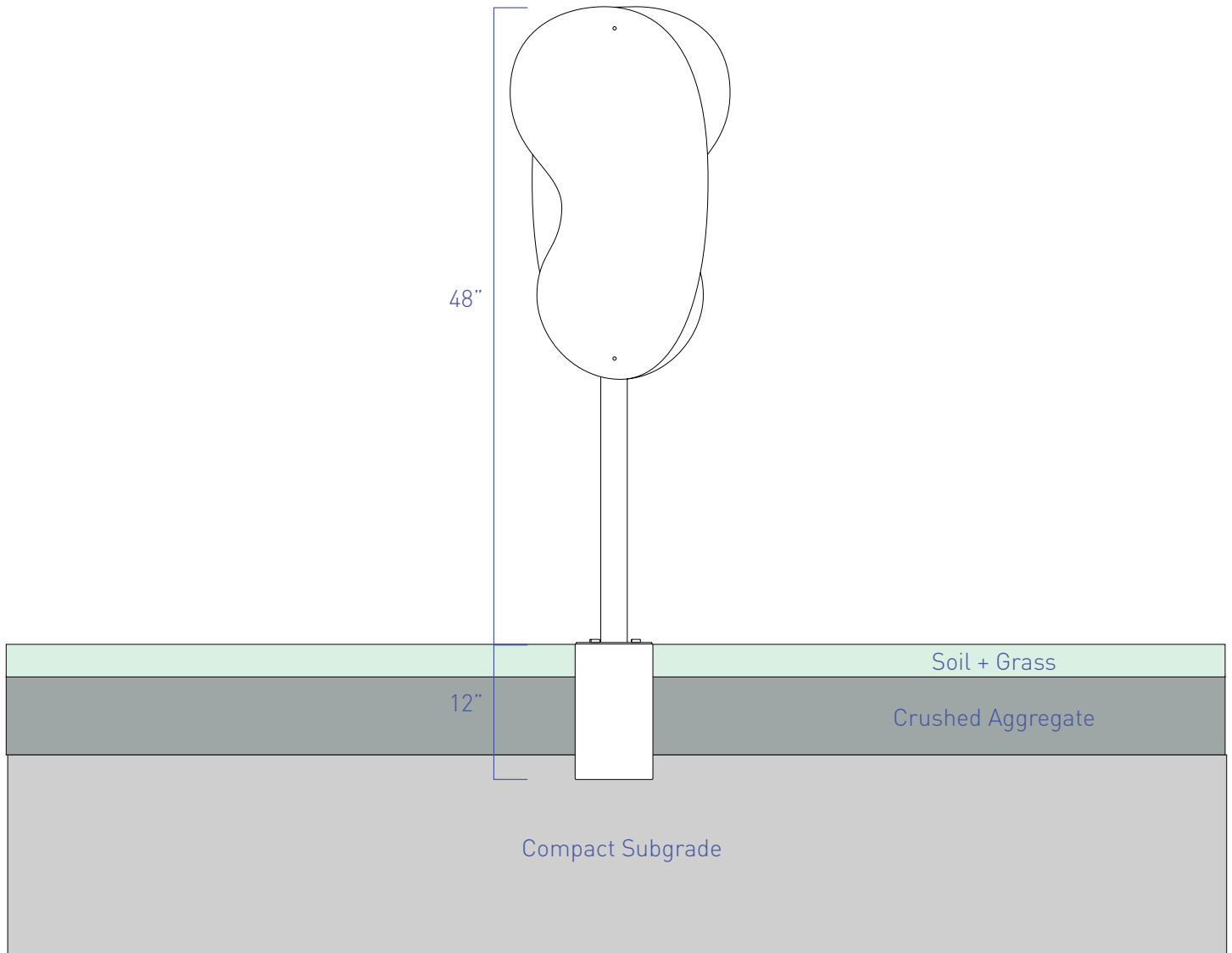

Modular Signage - Welcome to Fernhill Play Village



Fernhill Play Village

Nature Stage: Let Your Imagination Shine

Step onto the Nature Stage and become
an actor, director, or storyteller!
Choose a character, pick a setting,
and act out an exciting story with
your friends.



Fernhill Play Village

Nature Stage: Let Your Imagination Shine

Step onto the Nature Stage and become
an actor, director, or storyteller!
Choose a character, pick a setting,
and act out an exciting story with
your friends.



Modular Signage - ZigZag Beams



Fernhill Play Village

Zig Zag Beams: Spell with a hop, skip, and jump!

Hop from letter to letter to spell any word you choose. Or, take turns spelling; first to complete five words wins!



Fernhill Play Village

Zig Zag Beams: Spell with a hop, skip, and jump!

Hop from letter to letter to spell any word you choose. Or, take turns spelling; first to complete five words wins!



Fernhill Play Village

Play Village Sensory Maze: Feel Your Way to Fun!

Close your eyes and use your hands to follow the path.

Can you find two matching shapes without peeking?



Fernhill Play Village

Play Village Abacus: Play, Count, and Create!

Make a bead pattern for a friend to copy. Now, use the abacus to count the trees you see! How many people do you see?



Fernhill Play Village

Riverbed Crossing: Where Does River Water Come From?

Rivers carry water from many places! Some water starts as melted snow in the mountains, while other sources include rainfall and underground springs. Imagine how this water flows, shaping the land and creating homes for plants and animals along the way. Learn more by scanning the QR code below:



Fernhill Play Village

Riverbed Crossing: Leaf & Rock Challenge

Look closely at the bow and stern of the canoe. Find rocks or leaves along the riverbed that match these shapes and sizes! Collect and compare them! How many matches can you find?





Fernhill Play Village

Story Hills: Bring your stories to life

Every Story Begins Somewhere

Start at the first hill! Who is your
story about? Climb up and share!
What Happens Next?

At the second hill, add a twist or
challenge. Tell your adventure at
the top!



Fernhill Play Village

Story Hills: Bring your stories to life

Every Story Begins Somewhere

Start at the first hill! Who is your
story about? Climb up and share!
What Happens Next?

At the second hill, add a twist or
challenge. Tell your adventure at
the top!

Nature Stage - Log Bench



Log Benches - Technical Drawings

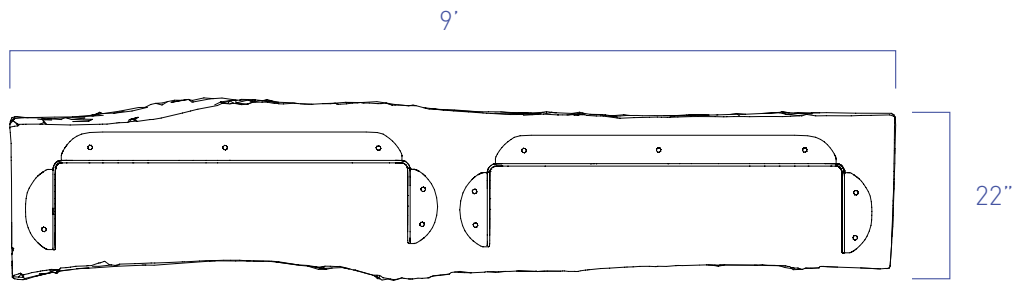

TOP VIEW



FRONT VIEW

SIDE VIEW

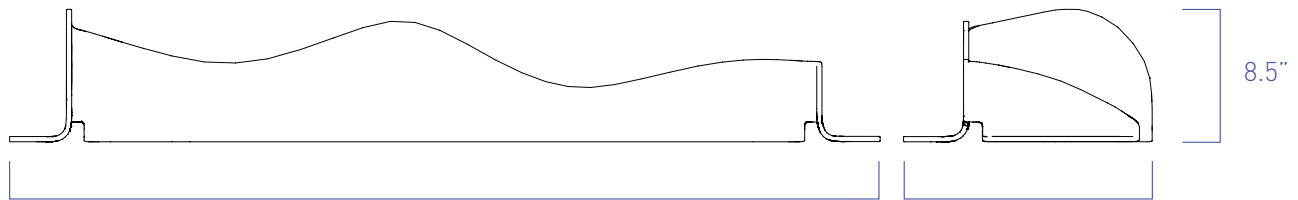

FRONT VIEW

SIDE VIEW

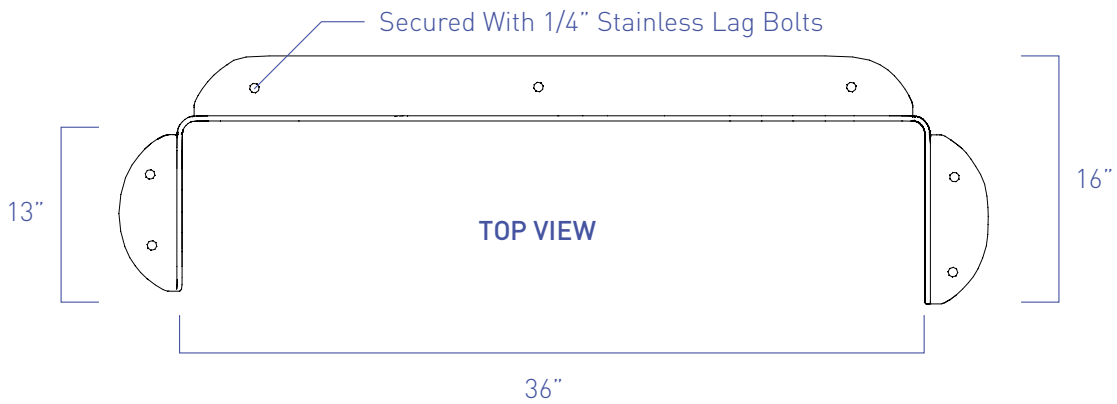

TOP VIEW

Contact

For questions about this research document please call or e-mail us:

Jaime Salm	jaime@letsfuturetogether.com	215.681.0909
Isaac Salm	isaac@letsfuturetogether.com	305.815.8330

The information contained in this document is intended only for the personal and confidential use of the recipient(s). This document may contain privileged and confidential information and/or work product. If the reader of this document is not the intended recipient or an agent responsible for delivering it to the intended recipient, you are hereby notified that you have received this document in error and that any review, dissemination, distribution, or copying of this document is strictly prohibited.