



Corporate Office: 142 Conchester Hwy. Aston, PA 19014
PA: 610-497-0111 NJ: 609-729-0200 DE: 302-777-5080
TOLL FREE: 888-651-SIGN
FAX: 610-497-0110

December 17, 2024

Philadelphia Art Commission
1515 Arch Street., 13th Floor
Philadelphia, PA 19102

Subject: 6100 Ridge Avenue
Remax Wall Signs

Please accept this proposal to erect two (2) non-illuminated wall signs for Remax Plus Realtors at 6100 Ridge Avenue. The property is on the corner of Ridge Avenue and Conarroe Street, and has just undergone a complete renovation, which includes two additional stories atop what was once a single-story building.

Remax is looking to erect one (1) wall sign on each street frontage, which will serve to identify their ground floor offices. Each sign will be 2'-1.5" tall x 11'-2" long = 23.72 square feet, with a 7" projection from each façade, as per the attached files.

Thank you.

A handwritten signature in blue ink that reads 'Gregory Feld'.

Greg Feld
KC Sign Company
142 Conchester Highway
Aston, PA 19014
610-497-0111
gfeld@kcsignco.com

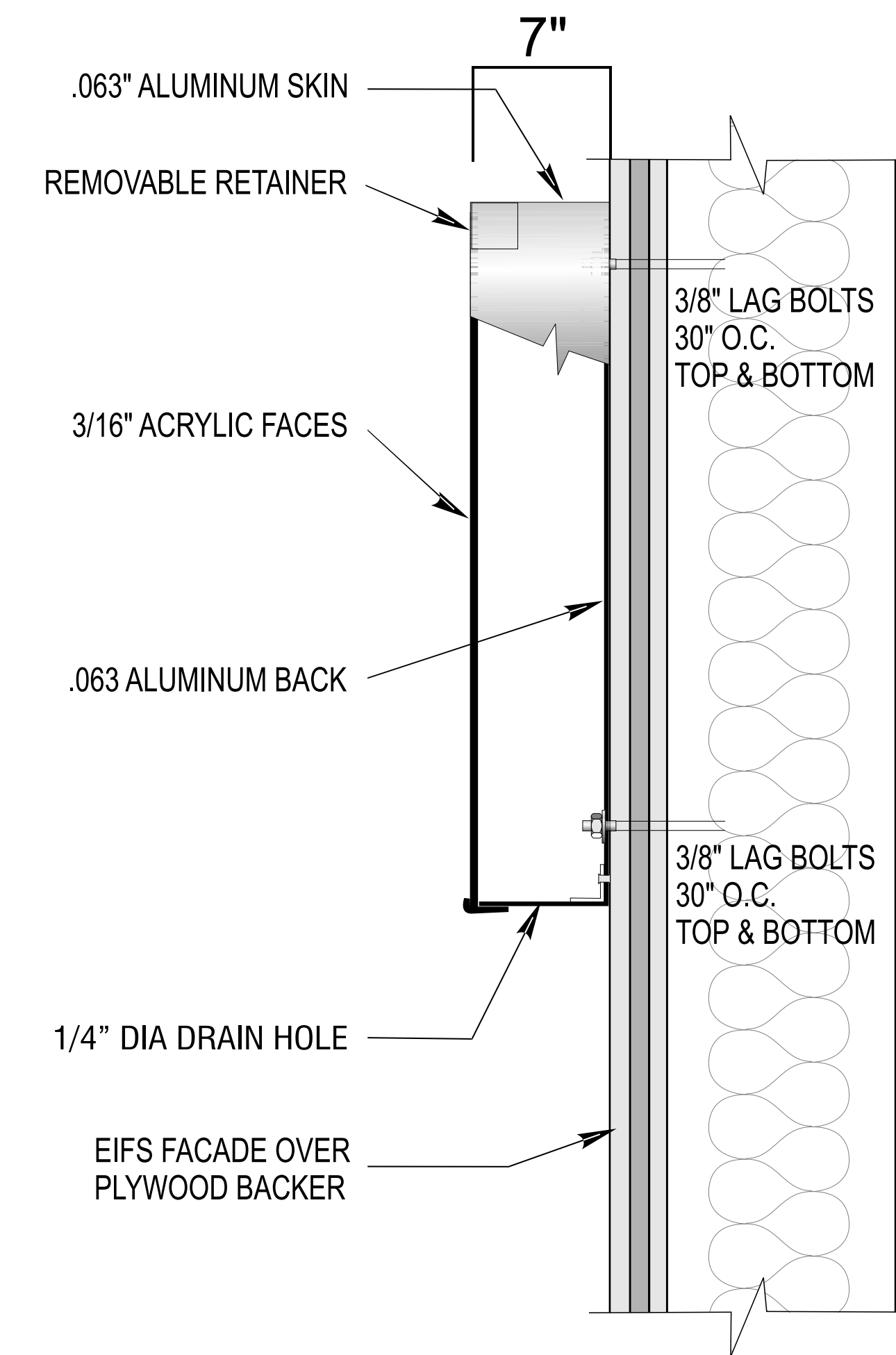
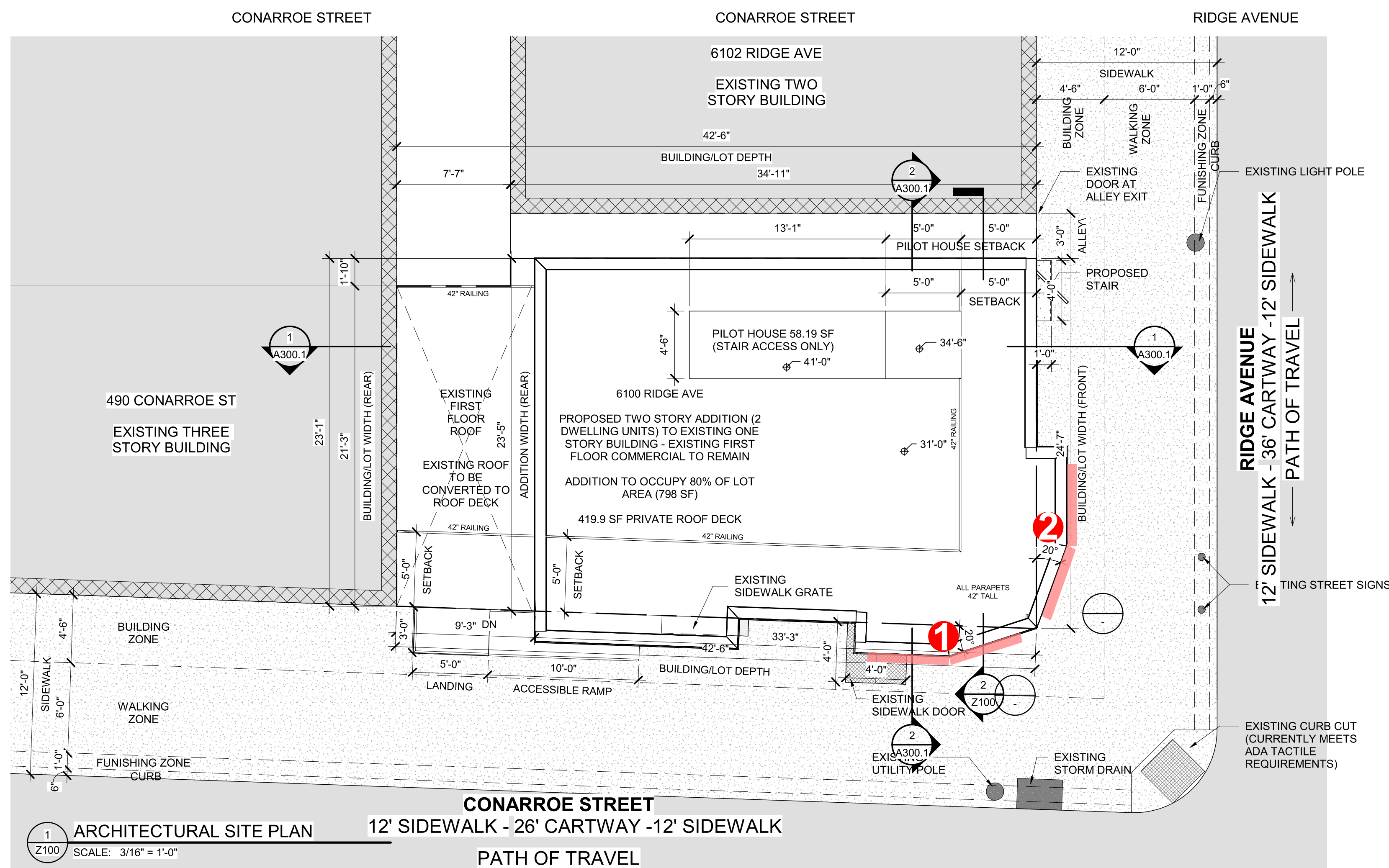

(2) 2'-1.5" x 11'-2" = 23.72 sq. ft. non-illuminated flat wall signs



QTY(1) NON-ILLUMINATED WALL SIGN facing Conarroe Street

25 1/2"(H) x 134"(L) = 3,417
3,417 / 144 = 23.72 SQFT **1**



QTY(1) NON-ILLUMINATED WALL SIGN facing Ridge Avenue

25 1/2"(H) x 134"(L) = 3,417
3,417 / 144 = 23.72 SQFT **2**

PROJECT NAME	PROJECT ADDRESS	PLAN NUMBER	DATE
Remax Plus	6100 Ridge Avenue Philadelphia, PA 19128	1	12/12/24



CONARROE STREET



CONARROE STREET

RIDGE AVENUE

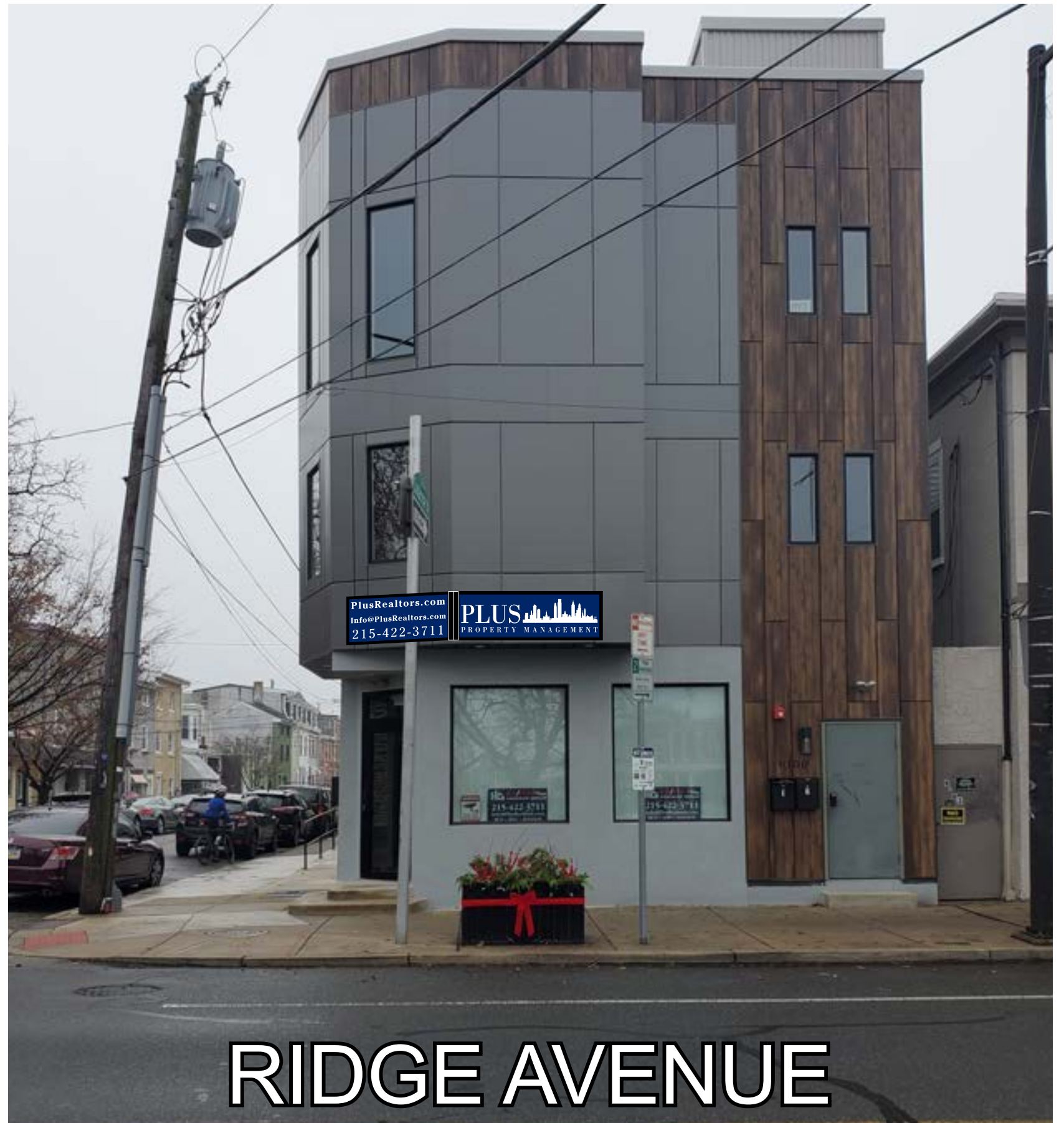

RIDGE AVENUE

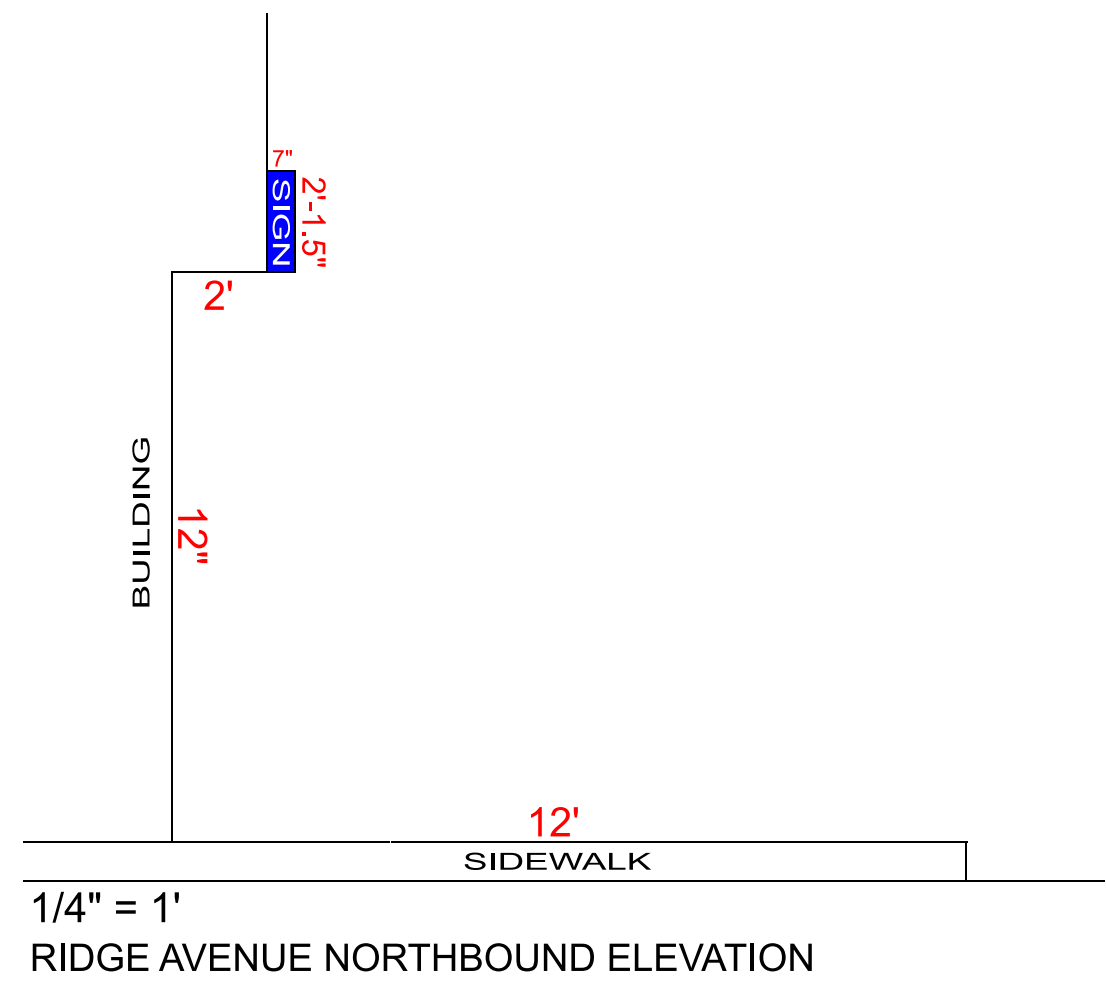

1/4" = 1'
RIDGE AVENUE NORTHBOUND ELEVATION

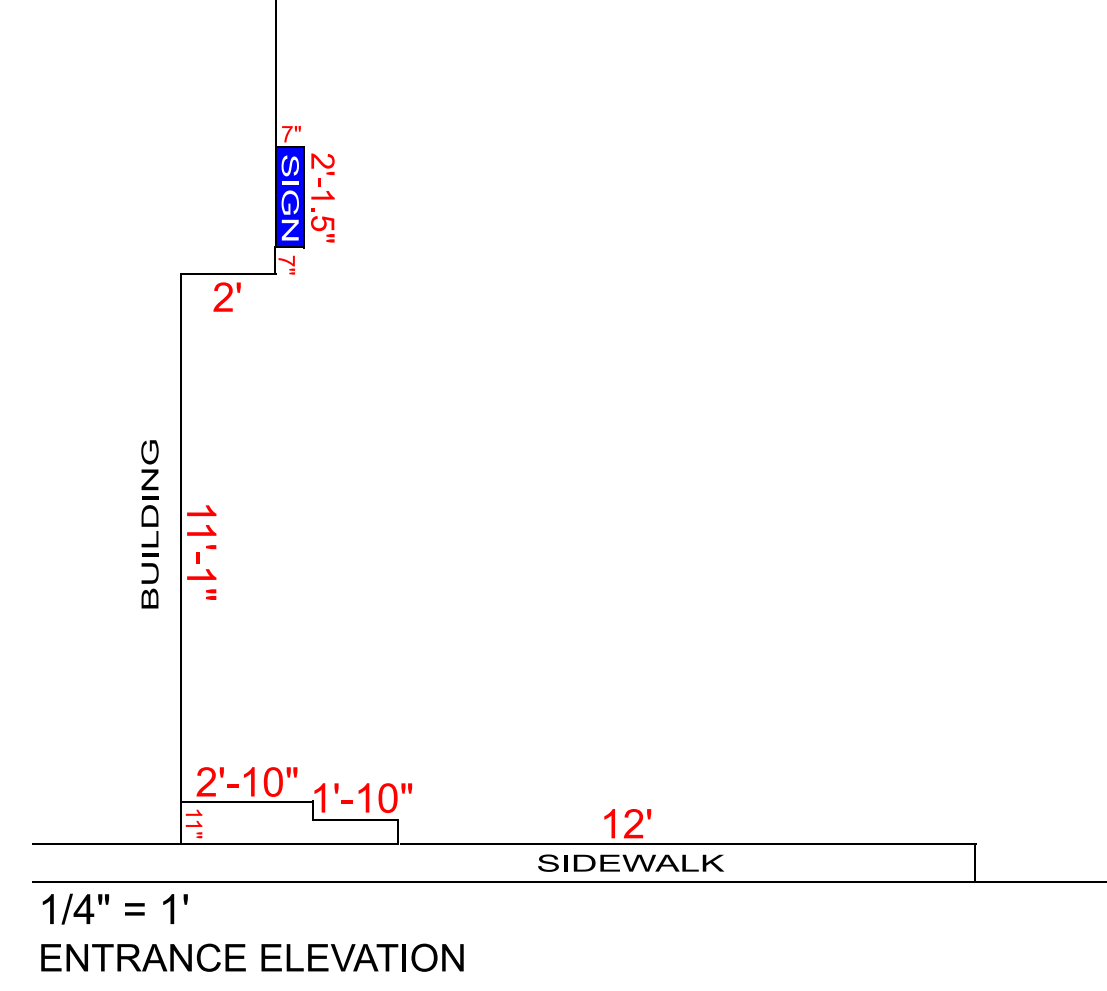

1/4" = 1'
ENTRANCE ELEVATION

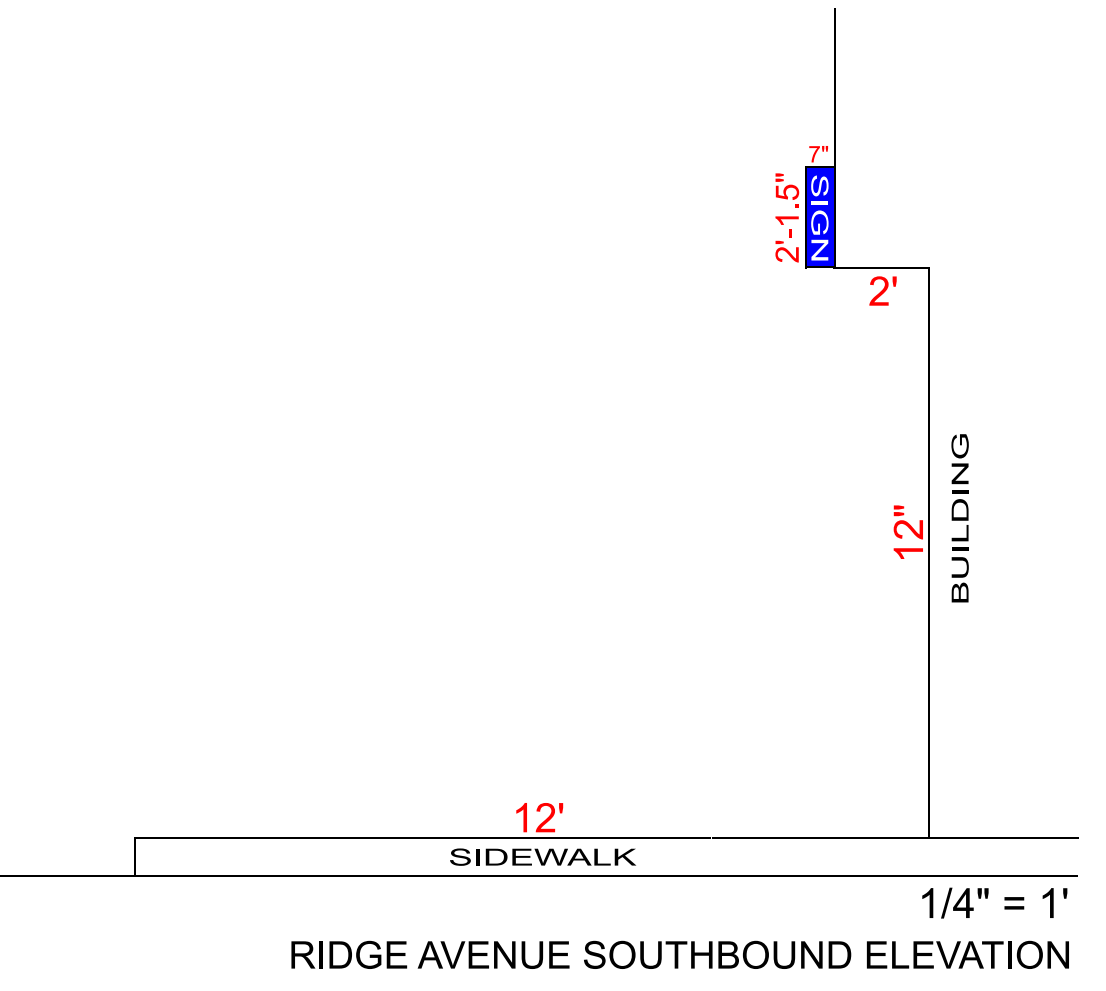

1/4" = 1'
RIDGE AVENUE SOUTHBOUND ELEVATION

PROJECT NAME	PROJECT ADDRESS	PLAN NUMBER	DATE
Remax Plus	6100 Ridge Avenue Philadelphia, PA 19128	2	12/12/24



FRONT VIEW



VIEW FROM FRONT DOOR ACROSS RIDGE AVE.

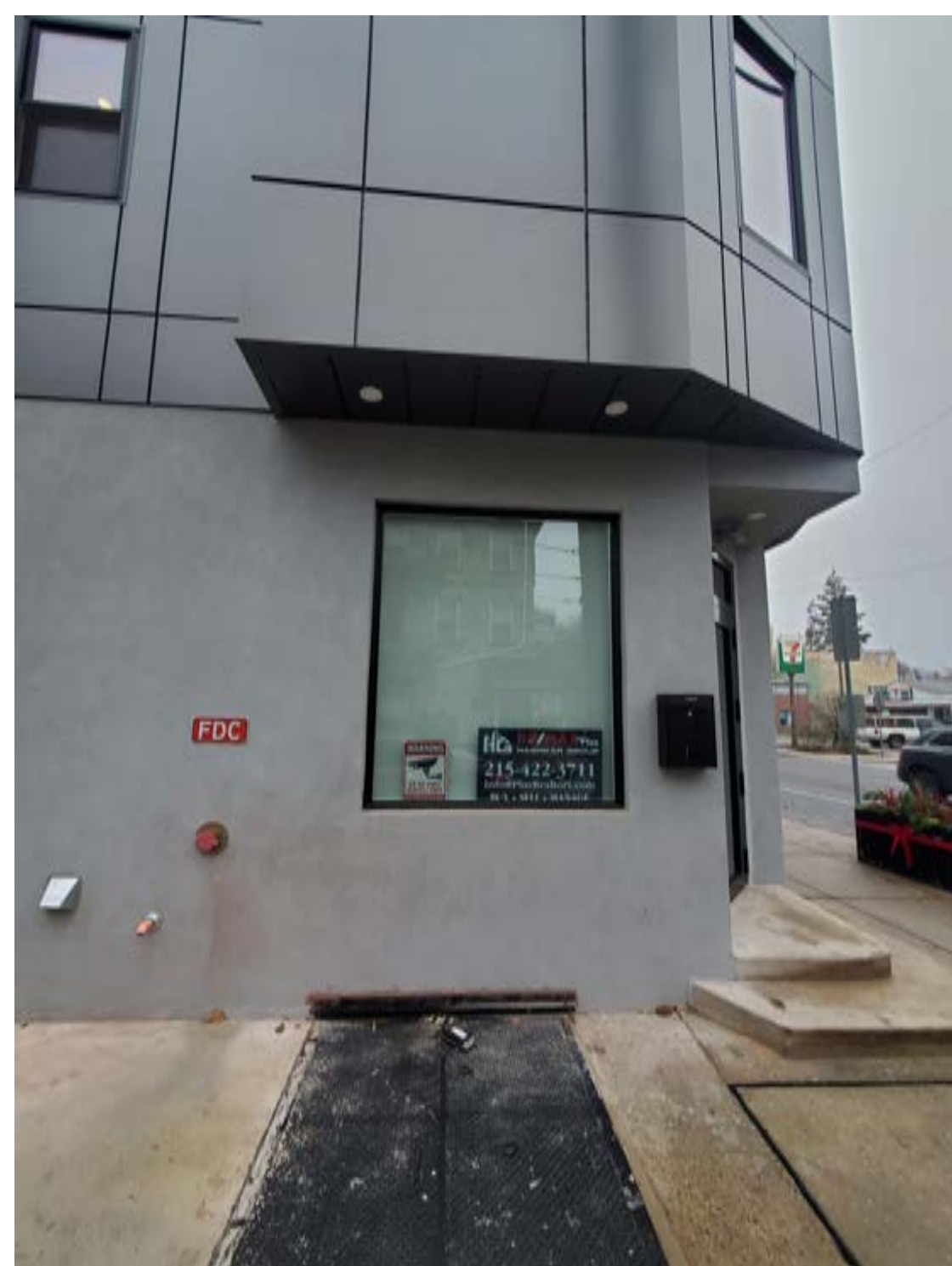

SIDE VIEWS



NORTHBOUND VIEW ON RIDGE AVE.



SOUTHBOUND VIEW ON RIDGE AVE.

PROJECT NAME	PROJECT ADDRESS	PLAN NUMBER	DATE
Remax Plus	6100 Ridge Avenue Philadelphia, PA 19128	3	12/12/24