

Equinox Health Club

1907 Walnut St. (Rittenhouse Square)
Philadelphia, PA

Project: 24-0129

D/F Projecting Blade Sign Qty: 02

Fabrication Information:
Produce (2) projecting blade signs as shown.

Installation Information:

Electrical Information:

600W Max 120/277V 5A Max Draw

Paint

P1 To Match PMS 432
P2 MP Metallic Satin Silver (951)

Date / Designer 07.16.24 - JHH

X:\SharedFiles\MISC PROPERTIES\Equinox

THIS DOCUMENT CONTAINS CONFIDENTIAL AND PROPRIETARY INFORMATION THAT CANNOT BE REPRODUCED OR DIVULGED, IN WHOLE OR IN PART, WITHOUT WRITTEN AUTHORIZATION FROM CITY SIGN SERVICE, INC. © 2021

Revisions

- R1 08.26.24 - JHH
- R2 11.04.24 - JHH
- R3 11.07.24 - JHH
- R4 00.00.00 -
- R5 00.00.00 -

CITY SIGN INC. SERVICE Interior / Exterior Sign Manufacturers

424 Caredean Dr.
Horsham PA, 19044
T. 215.442.1323
F. 215.442.1328

Sales: Jeff Carson

1. D/F ALUMINUM FRAMED & SKINNED PROJECTING BLADE SIGN PAINTED GRAY(P1)
2. 3" DEEP HALO-LIT ALUMINUM CHANNEL LETTERS PAINTED METALLIC SILVER(P2)
3. 3,000 K LED LIGHTING
4. 3/16" WHITE LEXAN BACKS
5. LETTERS MOUNTED TO BLADE SIGN VIA 1/4-20 STUDS & 1-1/2" STAND-OFFS
6. SECONDARY LEADS CARRIED TO INTERNALLY-MOUNTED POWER SUPPLIES
7. 120 OR 277 V PRIMARY ELECTRIC AT BOX LOCATION (PRIMARY BY OTHERS)
8. 4" X 4" X 3/8" GALVANIZED STEEL SQUARE TUBE OUTRIGGERS (BY OTHERS)
9. BLADE SIGN TO BE THRU-BOLTED TO MOUNTING PLATES WITH HARDWARE AS REQUIRED

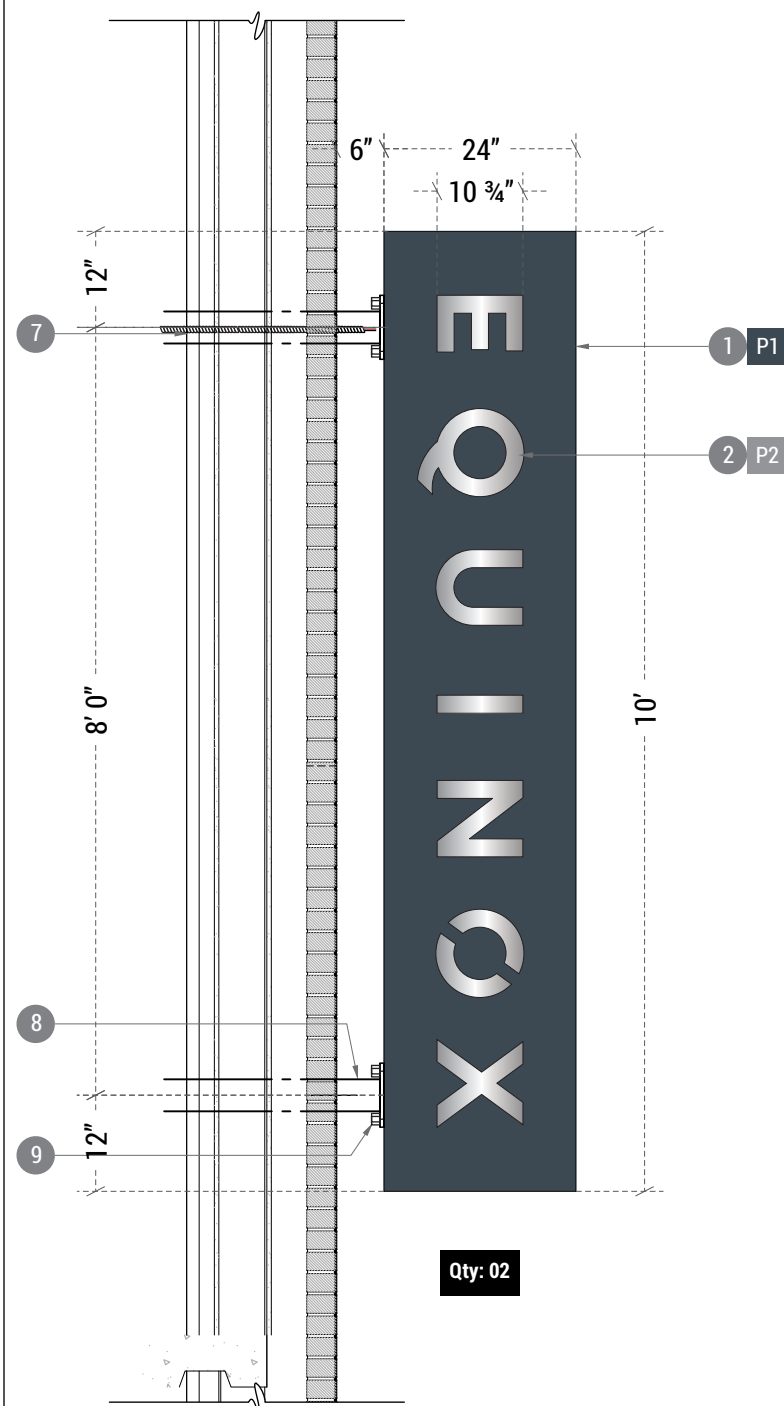

A D/F Projecting Sign w/ Halo-Lit Ltrs.
SCALE: 1/2"=1'-0"

20 SQ. FT.

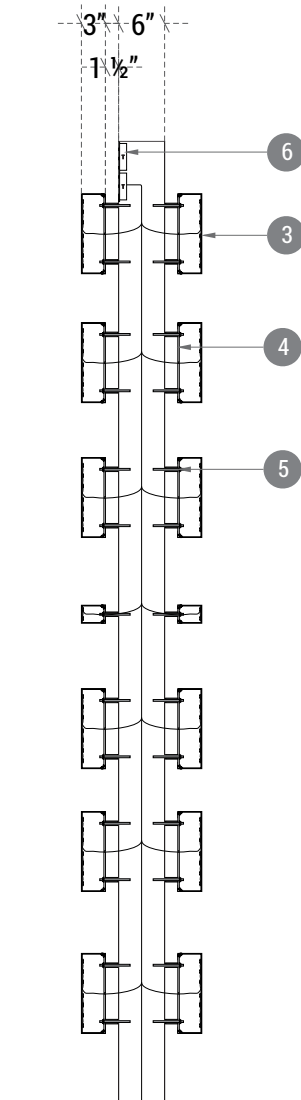

A.1 Section View
SCALE: 1/2"=1'-0"



A.2 D/F Sign - Side B
SCALE: 1/4"=1'-0"

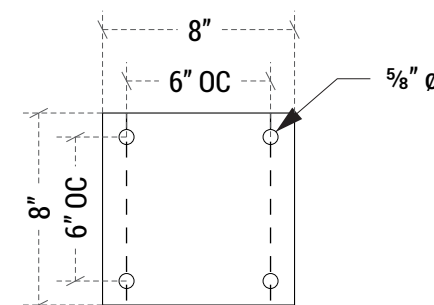

B Mounting Plate Detail
SCALE: 1 1/2"=1'-0"

LEGEND

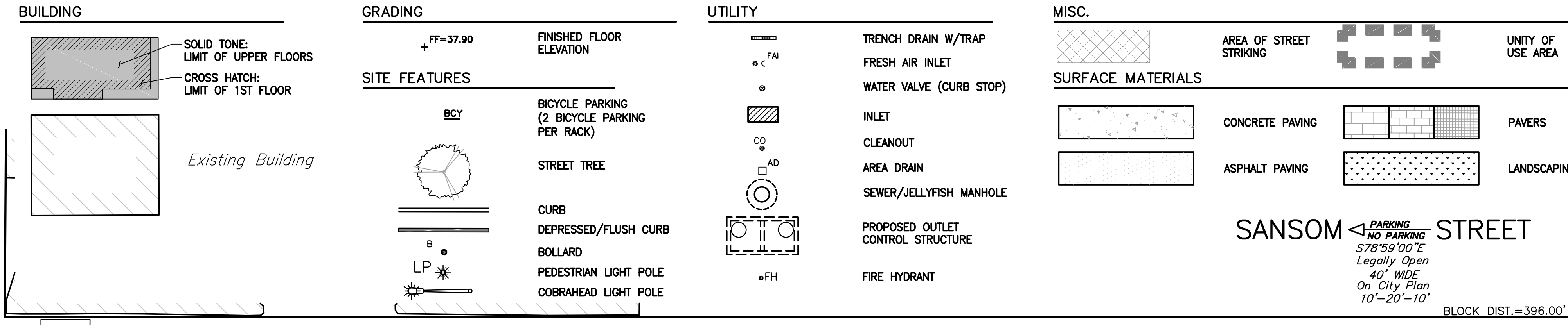

STREETS DEPARTMENT NOTES:

- 1. THE ACCEPTABLE CONSTRUCTION SPECIFICATIONS OF THE PHILADELPHIA STREETS DEPARTMENT ARE AS FOLLOWS: CONSTRUCTION ITEMS: PENNDOT PUBLICATION 408 CONSTRUCTION SPECIFICATIONS (MOST CURRENT EDITION) STREET LIGHTING: PHILADELPHIA STREETS DEPARTMENT STREET LIGHTING AND TRAFFIC DIVISION SPECIFICATIONS...

GENERAL NOTES:

- 1. THIS PLAN IS NOT TO BE USED FOR TITLE OR CONVEYANCE PURPOSES. 2. PLAN MADE AS PER INSTRUCTION OF APPLICANT, SOUTHERN LAND COMPANIES. 3. THIS PLAN WAS PREPARED FROM A FIELD SURVEY PERFORMED BY SAAS 3D SOLUTIONS ON AUGUST 12, 2015. ALL LOT LINE INFORMATION WAS PREPARED FROM DEED RECORDS...

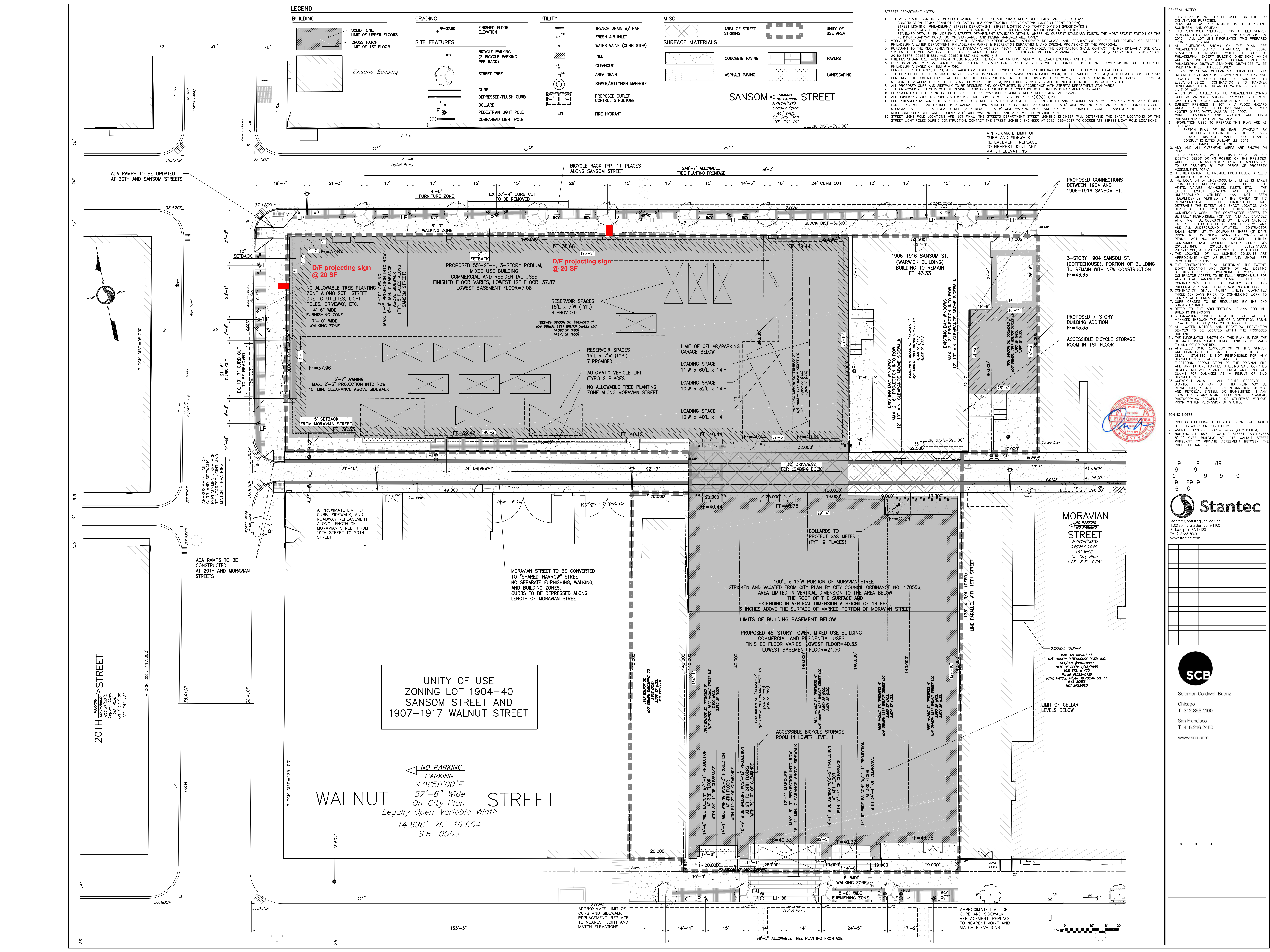

UNITY OF USE ZONING LOT 1904-40 SANSOM STREET AND 1907-1917 WALNUT STREET

WALNUT STREET 57'-6" Wide Legally Open Variable Width 14,896'-26"-16,604' S.R. 0003

ZONING NOTES: 1. PROPOSED BUILDING HEIGHTS BASED ON 0'-0" DATUM. 2. FF=43.33 ON CITY DATUM. 3. BUILDING AT 1907-15 WALNUT STREET CANTILEVERS 2'-0" OVER BUILDING AT 1917 WALNUT STREET...

Stantec logo and contact information: Stantec Consulting Services Inc. 150 Spring Garden, Suite 1100 Philadelphia PA 19130

SCB logo and contact information: Solomon Cordwell Buenz Chicago T 312.896.1100 San Francisco T 415.216.2450 www.scb.com

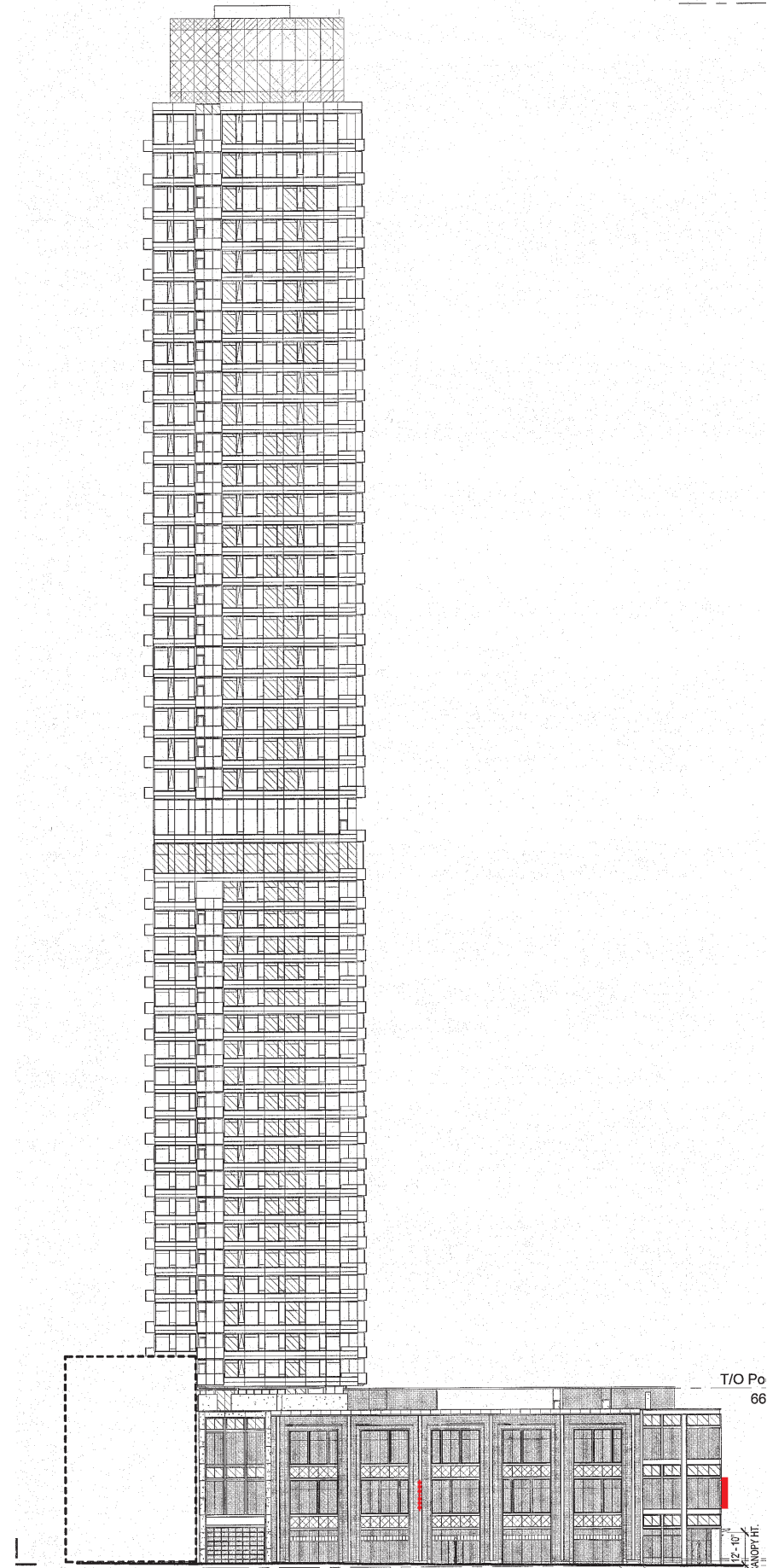

Samson St. with proposed projecting signs shown at scale in red

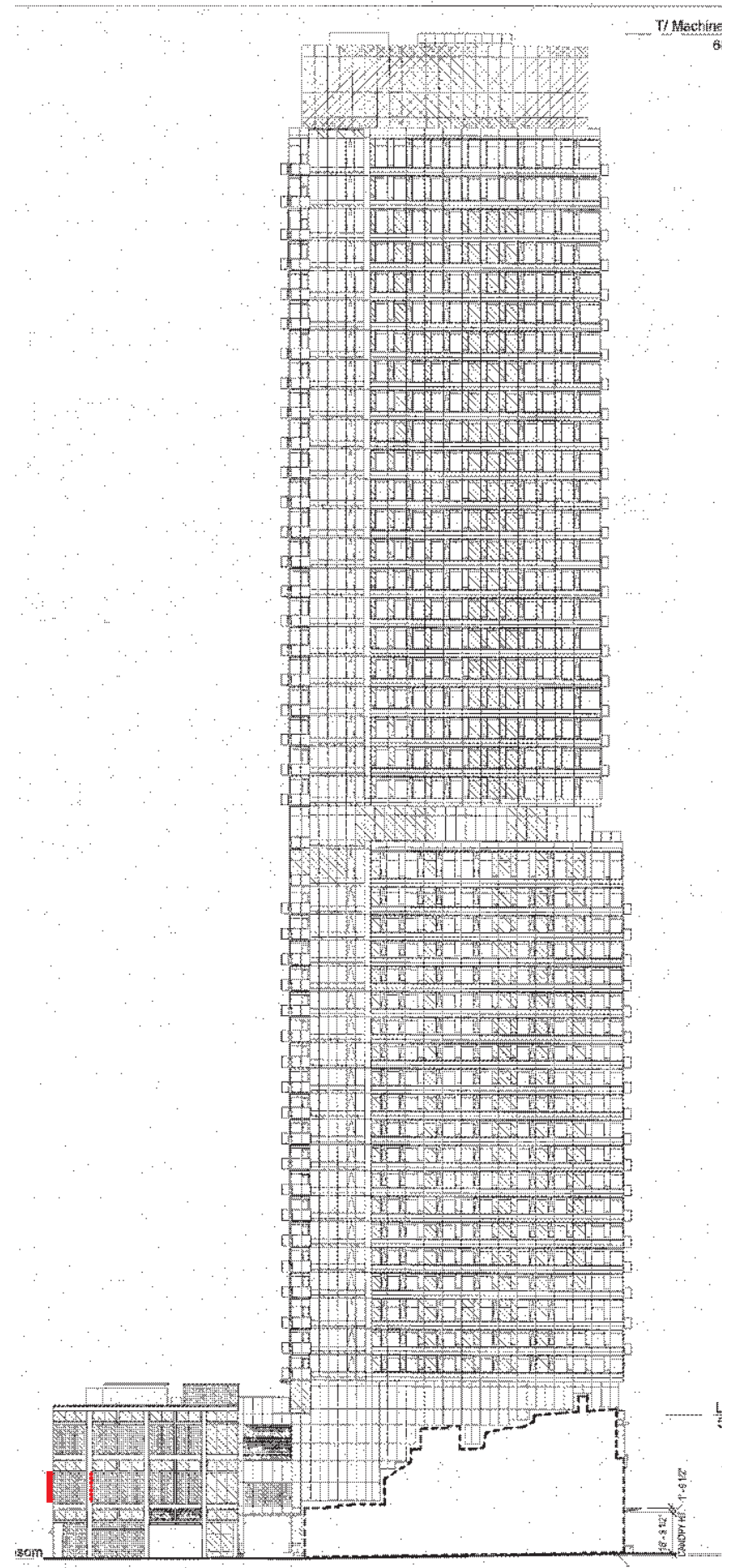

20th St. with proposed projecting signs shown at scale in red

Equinox Health Club

1907 Walnut St. (Rittenhouse Square)
Philadelphia, PA

Project: 24-0129

Site Plans



1 NORTH EXTERIOR ELEVATION AT SANSOM STREET
Scale: NTS

184' FRONTAGE. SIGN IS 20' 6" FROM GRADE TO BOTTOM OF SIGN. REPRESENTS .002 % OF TOTAL WALL FACADE. ONLY SIGN ON BUILDING ELEVATION.

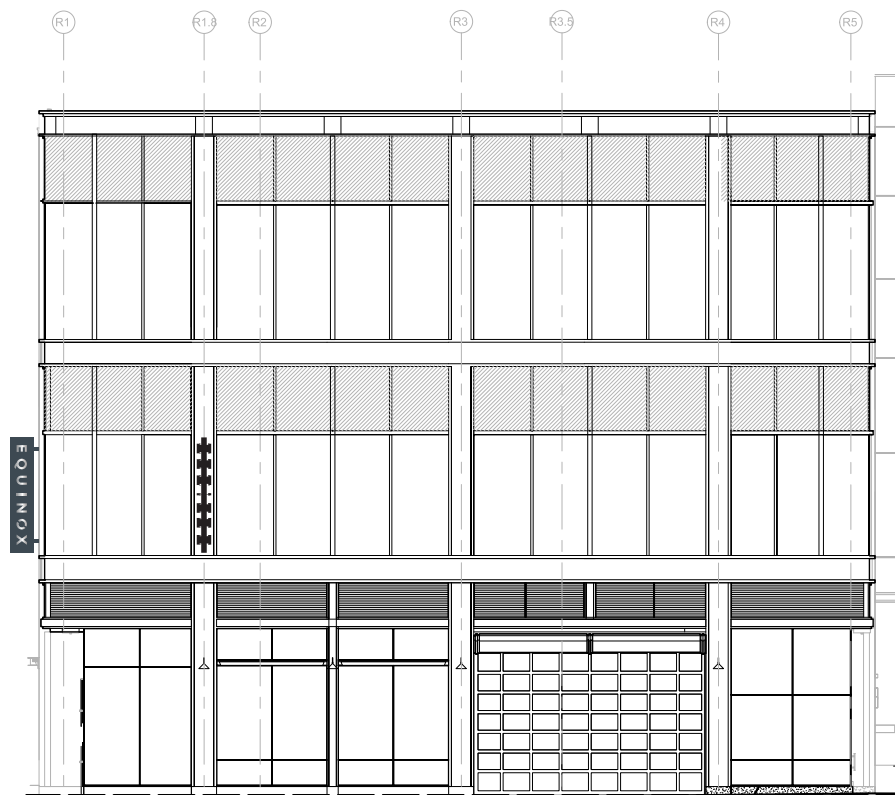

2 WEST EXTERIOR ELEVATION AT 20TH STREET
Scale: NTS

75' FRONTAGE. SIGN IS 20' 6" FROM GRADE TO BOTTOM OF SIGN. REPRESENTS .01 % OF TOTAL WALL FACADE. ONLY SIGN ON BUILDING ELEVATION.

Date / Designer 07.16.24 - JHH

X:\SharedFiles\MISC PROPERTIES\Equinox

THIS DOCUMENT CONTAINS CONFIDENTIAL AND PROPRIETARY INFORMATION THAT CANNOT BE REPRODUCED OR DIVULGED, IN WHOLE OR IN PART, WITHOUT WRITTEN AUTHORIZATION FROM CITY SIGN SERVICE, INC. © 2021

Revisions

- R1 08.26.24 - JHH
- R2 11.04.24 - JHH
- R3 11.07.24 - JHH
- R4 00.00.00 -
- R5 00.00.00 -



Interior / Exterior
Sign Manufacturers

424 Caredean Dr.
Horsham PA, 19044
T. 215.442.1323
F. 215.442.1328

Sales: Jeff Carson



Equinox Health Club

1907 Walnut St. (Rittenhouse Square)
Philadelphia, PA

Project: 24-0129

Renderings



Sansom St. Elevation

Date / Designer 07.16.24 - JHH

X:\SharedFiles\MISC PROPERTIES\Equinox

THIS DOCUMENT CONTAINS CONFIDENTIAL AND PROPRIETARY INFORMATION THAT CANNOT BE REPRODUCED OR DIVULGED, IN WHOLE OR IN PART, WITHOUT WRITTEN AUTHORIZATION FROM CITY SIGN SERVICE, INC. © 2021

Revisions

- R1 08.26.24 - JHH
- R2 11.04.24 - JHH
- R3 11.07.24 - JHH
- R4 00.00.00 -
- R5 00.00.00 -

CITY SIGN INC. SERVICE
Interior / Exterior Sign Manufacturers

424 Caredean Dr.
Horsham PA, 19044
T. 215.442.1323
F. 215.442.1328

Sales: Jeff Carson



Equinox Health Club

1907 Walnut St. (Rittenhouse Square)
Philadelphia, PA

Project: 24-0129

Renderings



Sansom St. Elevation

Date / Designer 07.16.24 - JHH

X:\SharedFiles\MISC PROPERTIES\Equinox

THIS DOCUMENT CONTAINS CONFIDENTIAL AND PROPRIETARY INFORMATION THAT CANNOT BE REPRODUCED OR DIVULGED, IN WHOLE OR IN PART, WITHOUT WRITTEN AUTHORIZATION FROM CITY SIGN SERVICE, INC. © 2021

Revisions

- R1 08.26.24 - JHH
- R2 11.04.24 - JHH
- R3 11.07.24 - JHH
- R4 00.00.00 -
- R5 00.00.00 -

CITY SIGN INC. Interior / Exterior Sign Manufacturers

424 Caredean Dr.
Horsham PA, 19044
T. 215.442.1323
F. 215.442.1328

Sales: Jeff Carson
  UNITED STATES SIGN COUNCIL

Equinox Health Club

1907 Walnut St. (Rittenhouse Square)
Philadelphia, PA

Project: 24-0129

Renderings



Sansom St. Elevation - Night View

Date / Designer 07.16.24 - JHH

X:\SharedFiles\MISC PROPERTIES\Equinox

THIS DOCUMENT CONTAINS CONFIDENTIAL AND PROPRIETARY INFORMATION THAT CANNOT BE REPRODUCED OR DIVULGED, IN WHOLE OR IN PART, WITHOUT WRITTEN AUTHORIZATION FROM CITY SIGN SERVICE, INC. © 2021

Revisions

- R1 08.26.24 - JHH
- R2 11.04.24 - JHH
- R3 11.07.24 - JHH
- R4 00.00.00 -
- R5 00.00.00 -



Interior / Exterior
Sign Manufacturers

424 Caredean Dr.
Horsham PA, 19044
T. 215.442.1323
F. 215.442.1328

Sales: Jeff Carson



Equinox Health Club

1907 Walnut St. (Rittenhouse Square)
Philadelphia, PA

Project: 24-0129

Renderings



Corner of Sansom St. & 20th St.

Date / Designer 07.16.24 - JHH

X:\SharedFiles\MISC PROPERTIES\Equinox

THIS DOCUMENT CONTAINS CONFIDENTIAL AND PROPRIETARY INFORMATION THAT CANNOT BE REPRODUCED OR DIVULGED, IN WHOLE OR IN PART, WITHOUT WRITTEN AUTHORIZATION FROM CITY SIGN SERVICE, INC. © 2021

Revisions

- R1 08.26.24 - JHH
- R2 11.04.24 - JHH
- R3 11.07.24 - JHH
- R4 00.00.00 -
- R5 00.00.00 -



Interior / Exterior
Sign Manufacturers

424 Caredean Dr.
Horsham PA, 19044
T. 215.442.1323
F. 215.442.1328

Sales: Jeff Carson





20th St. Elevation

Equinox Health Club

1907 Walnut St. (Rittenhouse Square)
Philadelphia, PA

Project: 24-0129

Renderings

Date / Designer 07.16.24 - JHH

X:\SharedFiles\MISC PROPERTIES\Equinox

THIS DOCUMENT CONTAINS CONFIDENTIAL AND PROPRIETARY INFORMATION THAT CANNOT BE REPRODUCED OR DIVULGED, IN WHOLE OR IN PART, WITHOUT WRITTEN AUTHORIZATION FROM CITY SIGN SERVICE, INC. © 2021

Revisions

- R1 08.26.24 - JHH
- R2 11.04.24 - JHH
- R3 11.07.24 - JHH
- R4 00.00.00 -
- R5 00.00.00 -



Interior / Exterior
Sign Manufacturers

424 Caredean Dr.
Horsham PA, 19044
T. 215.442.1323
F. 215.442.1328

Sales: Jeff Carson



Equinox Health Club

1907 Walnut St. (Rittenhouse Square)
Philadelphia, PA

Project: 24-0129

Renderings



20th St. Elevation - Night View

Date / Designer 07.16.24 - JHH

X:\SharedFiles\MISC PROPERTIES\Equinox

THIS DOCUMENT CONTAINS CONFIDENTIAL AND PROPRIETARY INFORMATION THAT CANNOT BE REPRODUCED OR DIVULGED, IN WHOLE OR IN PART, WITHOUT WRITTEN AUTHORIZATION FROM CITY SIGN SERVICE, INC. © 2021

Revisions

- R1 08.26.24 - JHH
- R2 11.04.24 - JHH
- R3 11.07.24 - JHH
- R4 00.00.00 -
- R5 00.00.00 -



Interior / Exterior
Sign Manufacturers

424 Caredean Dr.
Horsham PA, 19044
T. 215.442.1323
F. 215.442.1328

Sales: Jeff Carson



Equinox Health Club

1907 Walnut St. (Rittenhouse Square)
Philadelphia, PA

Project: 24-0129

Renderings



Corner of Sansom St. & 20th St. - Night View

Date / Designer 07.16.24 - JHH

X:\SharedFiles\MISC PROPERTIES\Equinox

THIS DOCUMENT CONTAINS CONFIDENTIAL AND PROPRIETARY INFORMATION THAT CANNOT BE REPRODUCED OR DIVULGED, IN WHOLE OR IN PART, WITHOUT WRITTEN AUTHORIZATION FROM CITY SIGN SERVICE, INC. © 2021

Revisions

- R1 08.26.24 - JHH
- R2 11.04.24 - JHH
- R3 11.07.24 - JHH
- R4 00.00.00 -
- R5 00.00.00 -



Interior / Exterior
Sign Manufacturers

424 Caredean Dr.
Horsham PA, 19044
T. 215.442.1323
F. 215.442.1328

Sales: Jeff Carson



UNITED STATES
SIGN COUNCIL

01.12







