

ADDRESS: 310 S 16TH ST

Proposal: Install Fibrex windows

Review Requested: Final Approval

Owner: Aileen and Mark Andrews

Applicant: James Sirio, Renewal by Andersen

History: 1850

Individual Designation: None

District Designation: Rittenhouse Fidler Historic District, Contributing, 2/8/1995

Staff Contact: Dan Shachar-Krasnoff, daniel.shachar-krasnoff@phila.gov

OVERVIEW: This application proposes installing seven Andersen Fibrex windows on the front façade and three on the rear façade. The proposed six-over-six, simulated-divided-light windows do not match the original in materials. The section drawings provided are inaccurate; the existing brickmold is misrepresented and the existing frame is shown although the description calls the project a full-frame replacement. The existing door, door surround, brickmold, and windows at the front façade are not original in design or configuration. The existing brickmold can remain because it is grandfathered, but, if it is removed, it should be replaced with an appropriate clamshell brickmold. Screens on the Fibrex windows are typically set forward in the openings, which are inappropriate for historic windows.

SCOPE OF WORK:

- Install Fibrex windows.

STANDARDS FOR REVIEW:

The Secretary of the Interior's Standards for the Treatment of Historic Properties and Guidelines include:

- *Standard 6: Deteriorated historic features will be repaired rather than replaced. Where the severity of deterioration requires replacement of a distinctive feature, the new feature will match the old in design, color, texture, and, where possible, materials. Replacement of missing features will be substantiated by documentary and physical evidence.*
 - The application provides insufficient and conflicting details on the installation of the windows, failing to satisfy Standard 6.
 - The Fibrex material and design of the screens are incompatible with the historic district, failing to satisfy Standard 6.

STAFF RECOMMENDATION: Denial, pursuant to Standard 6 and owing to incompleteness.



Historic Property – Approval Documentation Form

This form must accompany any eCLIPSE application for a historic property that does not require drawings.

Project Address & Scope

Applicant: Enter the location of work and scope for the permit. Then email form to Historical Commission staff at preservation@phila.gov

State the legal address of the historically designated property and describe the proposed work in detail. Attach additional sheets if needed.

1

Address: 310 S. 16th St., Philadelphia PA 19102

Project Scope: Replace 10 windows - 7 on front, 3 on back. Same styles and sizes, change in color and material.

Applicant Declaration & Signature

By submitting this form, the undersigned hereby agrees to comply with all conditions selected by PHC staff below. Failure to comply may result in processing delays or permit revocation.

Name: Maggie McDevitt, Renewal by Andersen (please print) Title: HDA/Historic Coordinator

Signature: Maggie McDevitt Date: 8/27/24

PHC Conditions (for PHC staff use only)

Each selected condition is a requirement for this permit application.

Conditions must be complied with before issuance of any Certificate of Approval or Certificate of Occupancy.

Where review of shop drawings or a field sample is required the responsible party must coordinate review with Historical Commission staff by emailing preservation@phila.gov.

2

Restrictions & Limitations:

- No exterior work permitted as part of this permit.
- No work to the windows and / or exterior doors as part of this permit.
- No work to the front façade as part of this permit.

PHC Staff Review of the following required for final approval:

- Window shop drawings
- Door shop drawings
- Shutter shop drawings
- Roof specifications and sample
- Cornice details and shop drawings
- Brick, stone or other masonry sample required in the field
- Masonry pointing sample required in the field
- Masonry cut-out sample required in the field
- Masonry cleaning sample required in the field
- Paint removal sample (3 ft x 3 ft) required in the field
- Signage, awning structure and / or light fixture details.
- _____ specifications.
- _____ to be salvaged and re-installed.
- Other:

Philadelphia Historical Commission Approval (for PHC staff use only)

Signature: _____ Approval Date: _____

APPLICATION FOR BUILDING PERMIT



CITY OF PHILADELPHIA
 DEPARTMENT OF LICENSES AND INSPECTIONS
 MUNICIPAL SERVICES BUILDING - CONCOURSE
 1401 JOHN F. KENNEDY BOULEVARD
 PHILADELPHIA, PA 19102
 For more information visit us at www.phila.gov

APPLICATION # _____

(Please complete all information below and print clearly)

ADDRESS OF PROPOSED CONSTRUCTION

310 S. 16th St., Philadelphia PA 19102

APPLICANT:

Maggie McDevitt

COMPANY NAME: Renewal by Andersen

PHONE # 610 228 2183 FAX # 215 307 4881

APPLICANT'S ADDRESS:

761 5th Ave Suite 3

King of Prussia PA 19406

LICENSE # 37492

E-MAIL: mmcdevitt@renewalphilly.com

PROPERTY OWNER'S NAME:

Aileen + Mark Andrews

PHONE # 214 - 458 - 4941 FAX #

PROPERTY OWNER'S ADDRESS:

310 S. 16th St.

Philadelphia PA 19102

ARCHITECT / ENGINEER IN RESPONSIBLE CHARGE:

ARCHITECT / ENGINEERING FIRM:

ARCHITECT / ENGINEERING FIRM ADDRESS:

PHONE #

FAX #

LICENSE #

E-MAIL:

CONTRACTOR:

Renewal by Andersen at Greater Phila.

CONTRACTING COMPANY:

Renewal by Andersen

PHONE # 610 228 2183 FAX # 215 307 4881

CONTRACTING COMPANY ADDRESS:

761 5th Ave Suite 3

King of Prussia PA 19406

LICENSE # 37492

E-MAIL: mmcdevitt@renewalphilly.com

USE OF BUILDING / SPACE:

Residential

ESTIMATED COST OF WORK

\$ 34,299.⁰⁰

BRIEF DESCRIPTION OF WORK:

Replace 10 windows - same styles, and sizes; change color & material. 7 on front of home (2 first fl; 2 second fl; 2 third fl; 1 fourth fl) and 3 on back of home (1 second floor, 1 3rd third fl; 1 fourth fl). Please see attached documents for more details.

TOTAL AREA UNDERGOING CONSTRUCTION: _____ square feet

COMPLETE THESE ITEMS IF APPLICABLE TO THIS APPLICATION:

OF NEW SPRINKLER HEADS (suppression system permits only): _____ LOCATION OF SPRINKLERS: _____

OF NEW REGISTERS / DIFFUSERS (hvac / ductwork permits only): _____ LOCATION OF STANDPIPES: _____

IS THIS APPLICATION IN RESPONSE TO A VIOLATION? NO YES VIOLATION #: _____

All provisions of the building code and other City ordinances will be complied with, whether specified herein or not. Plans approved by the Department form a part of this application. I hereby certify that the statements contained herein are true and correct to the best of my knowledge and belief. I further certify that I am authorized by the owner to make the foregoing application, and that, before I accept my permit for which this application is made, the owner shall be made aware of all conditions of the permit. I understand that if I knowingly make any false statement herein I am subject to such penalties as may be prescribed by law or ordinance.

APPLICANT'S SIGNATURE Maggie McDevitt

DATE: 8, 27, 24

PRE-REQUISITE APPROVALS FOR:

ADDRESS:

APPLICATION #:

√ IF REQ'D	AGENCY	INITIALS	DATE	REMARKS
	ART COMMISSION 13 TH FLOOR - 1515 ARCH STREET			
	CITY PLANNING COMMISSION 13 TH FLOOR - 1515 ARCH STREET			
	HISTORICAL COMMISSION 13 TH FLOOR - 1515 ARCH STREET			
	FAIRMOUNT PARK COMMISSION			
	<input type="checkbox"/> CITY <input type="checkbox"/> STATE AIR MANAGEMENT / HEALTH DEPARTMENT STREETS DEPARTMENT ROOM 940 - M.S.B.			
	WATER DEPARTMENT 2 ND FLOOR - 1101 MARKET STREET			
	EMERGENCY SERVICES & ABATEMENT UNIT ROOM 1140 - M.S.B.			
	ZONING			

WAS VIOLATION FOR WORK WITHOUT A PERMIT? NO YES (INSPECTION FEE MUST BE ADDED TO PERMIT FEE)

VIOLATION # _____



August 2024

To: City of Philadelphia Historical Commission

From: Renewal by Andersen (contractor) on behalf of Aileen & Mark Andrews (owners)

Re: Window replacement at 310 S. 16th St., Philadelphia, PA 19102

We are proposing the following work at the home of Aileen and Mark Andrews: **replacement of 10 windows.**

A list of applicable materials can be found on next page; details of the new units are as follows:

10 Renewal by Andersen (RbA) Acclaim™ double-hung windows. Fibrex windows with equal sash, Sandtone exterior, and full-divided-light (FDL) grilles in a Colonial pattern of 3 lights across by 2 lights down (3x2) on each sash. Full-sized TruScene screen on each unit. *7 units are located on the front; 3 units are located on the back.*

This will be a full frame replacement. The new units have measured to fit in the existing and openings; there is no need to alter the size of the existing openings. During the installation process it is common practice for us to inspect an opening after the existing unit is removed in order to ensure that the area surrounding the unit is in good shape. Any rot or damage found during that process will be addressed during the installation. Any and all debris created during installation will be handled by our crew and cleaned up before we leave the property.

I am including pertinent information from our catalog for your review, as well as supplemental documents specific to this project. If you need anything further, please do not hesitate to contact me.

Maggie McDevitt

HOA/Historic Coordinator

610-228-2183

mmcdevitt@renewalphilly.com

761 5th Ave., Suite 3
King of Prussia, PA 19406
Ph.: 215-307-4880
Fax: 215-307-4881
www.renewalbyandersen.com

Materials Checklist

Aileen & Mark Andrews

310 S 16th St

Philadelphia, PA 19102

H: (214)458-4941

C: (214)458-4941

CATEGORY	DESCRIPTION	QUANTITY	
<hr/>			
This list includes the sum total all of the materials for the entire job.			
<hr/>			
LUMBER	1 x 4 x 8' Primed - 8ft	.. 10 unit	<input type="checkbox"/>
LUMBER	5/4 x 4 x 8' Primed - 8ft	.. 10 unit	<input type="checkbox"/>
<hr/>			
MATERIALS	Caulk - Exterior Clear	.. 10 tube	<input type="checkbox"/>
MATERIALS	Caulk - Exterior Sandtone	.. 10 tube	<input type="checkbox"/>
MATERIALS	Coil - COLORED RBA Sandtone 416	.. 2 rolls	<input type="checkbox"/>
MATERIALS	Foam	.. 20 cans	<input type="checkbox"/>
MATERIALS	Ice & Water Shield 6"	.. 10 ft	<input type="checkbox"/>
MATERIALS	Paintable Caulk - White	.. 10 tube	<input type="checkbox"/>
<hr/>			
TRIM	Bullnose - 5/8 x 7/8 - Primed - 8ft	.. 16 x 8ft	<input type="checkbox"/>
<hr/>			
CUSTOM	Insta trim - White - 8'	.. 8 PER UNIT	<input type="checkbox"/>
<hr/>			



310 S. 16TH ST.
WINDOWS PROPOSED FOR REPLACEMENT
(WIDE VIEWS OF FRONT AND BACK ON LEFT; CLOSE-UP VIEWS OF FRONT ON RIGHT)

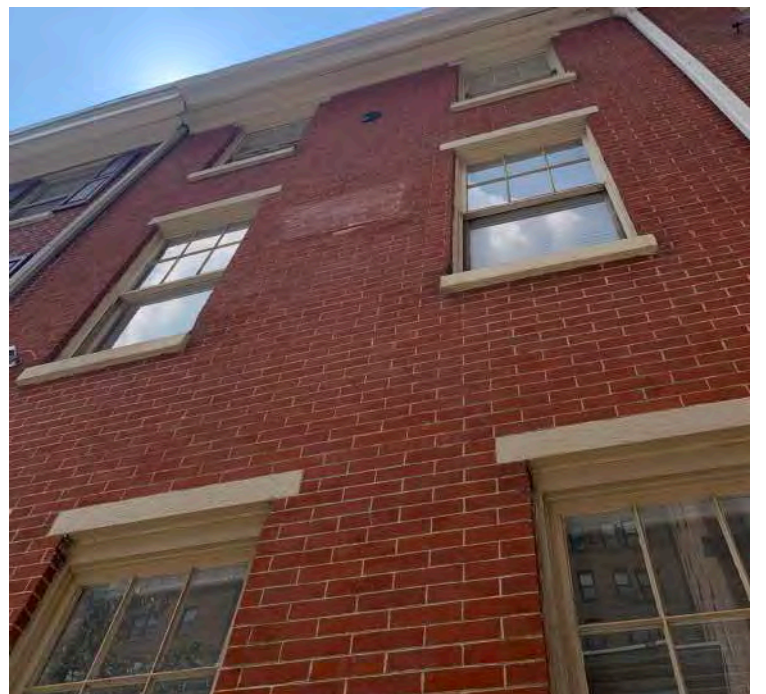



~2 PROPERTIES TO LEFT OF 310 S. 16TH ST.

~2 PROPERTIES TO RIGHT OF 310 S. 16TH ST.

PROPERTIES SURROUNDING 310 S. 16TH ST.



~4 PROPERTIES ACROSS FROM 310 S. 16TH ST.





PROPOSED NEW DOUBLE-HUNG
 EQUAL SASH, SANDTONE EXTERIOR
 FULL-DIVIDED-LIGHT GRILLES 3x2 PER SASH
 SIZE: 29^{5/8}"x51^{1/4}" (SAME AS EXISTING)
 1 UNIT WITH THIS SIZE/AESTHETIC



PROPOSED NEW DOUBLE-HUNG
 EQUAL SASH, SANDTONE EXTERIOR
 FULL-DIVIDED-LIGHT GRILLES 3x2 PER SASH
 SIZE: 32^{5/8}"x51^{1/4}" (SAME AS EXISTING)
 3 UNITS WITH THIS SIZE/AESTHETIC



PROPOSED NEW DOUBLE-HUNG
 EQUAL SASH, SANDTONE EXTERIOR
 FULL-DIVIDED LIGHT GRILLES 3x2 PER SASH
 SIZE: 34"x53" (SAME AS EXISTING)
 2 UNITS WITH THIS SIZE/AESTHETIC



PROPOSED NEW DOUBLE-HUNG
 EQUAL SASH, SANDTONE EXTERIOR
 FULL-DIVIDED-LIGHT GRILLES 3x2 PER SASH
 SIZE: 31^{5/8}"x69^{1/4}" (SAME AS EXISTING)
 2 UNITS WITH THIS SIZE/AESTHETIC



PROPOSED NEW DOUBLE-HUNG
 EQUAL SASH, SANDTONE EXTERIOR
 FULL-DIVIDED-LIGHT GRILLES 3x2 PER SASH
 SIZE: 35^{5/8}"x68^{7/8}" (SAME AS EXISTING)
 2 UNITS WITH THIS SIZE/AESTHETIC

Double-Hung WINDOWS

This classic window style is an excellent choice no matter where you live. Choose gently curved Contemporary or squared Traditional Check Rails.

CONVENIENT

Both top and bottom sash tilt in for easy cleaning.

ELEGANT

The traditional look of mortise-and-tenon joints complements any decor.

ACCURATE

Fits perfectly in many restoration and renovation projects.

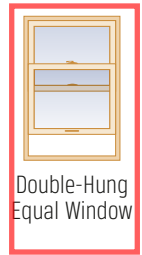

Double-Hung Equal Window



Double-Hung Cottage Style Window

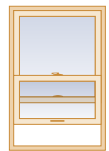

Double-Hung Reverse Cottage Style Window



Combination Window

EXPRESS YOUR STYLE

Check Rail Options

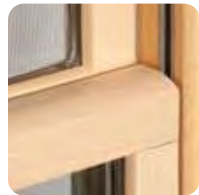

Contemporary



Traditional

Reverse cottage style windows feature a larger upper sash



“My new windows look beautiful and can be opened from the bottom or top.”
CAROL P.

Double-Hung Windows / White Interior



Double-Hung Windows / White Interior / Colonial Grilles



Double-Hung Reverse Cottage Style Windows
Maple Interior / Modified Prairie Grilles



Double-Hung Windows / White Interior



Double-Hung Cottage Style and Picture Combination Window / White Interior / Colonial Grilles



Double-Hung Windows / White Exterior / Colonial Grilles

EXPLODED VIEW

DG DOUBLE-HUNG WINDOW

DG DOUBLE HUNG COMPONENTS

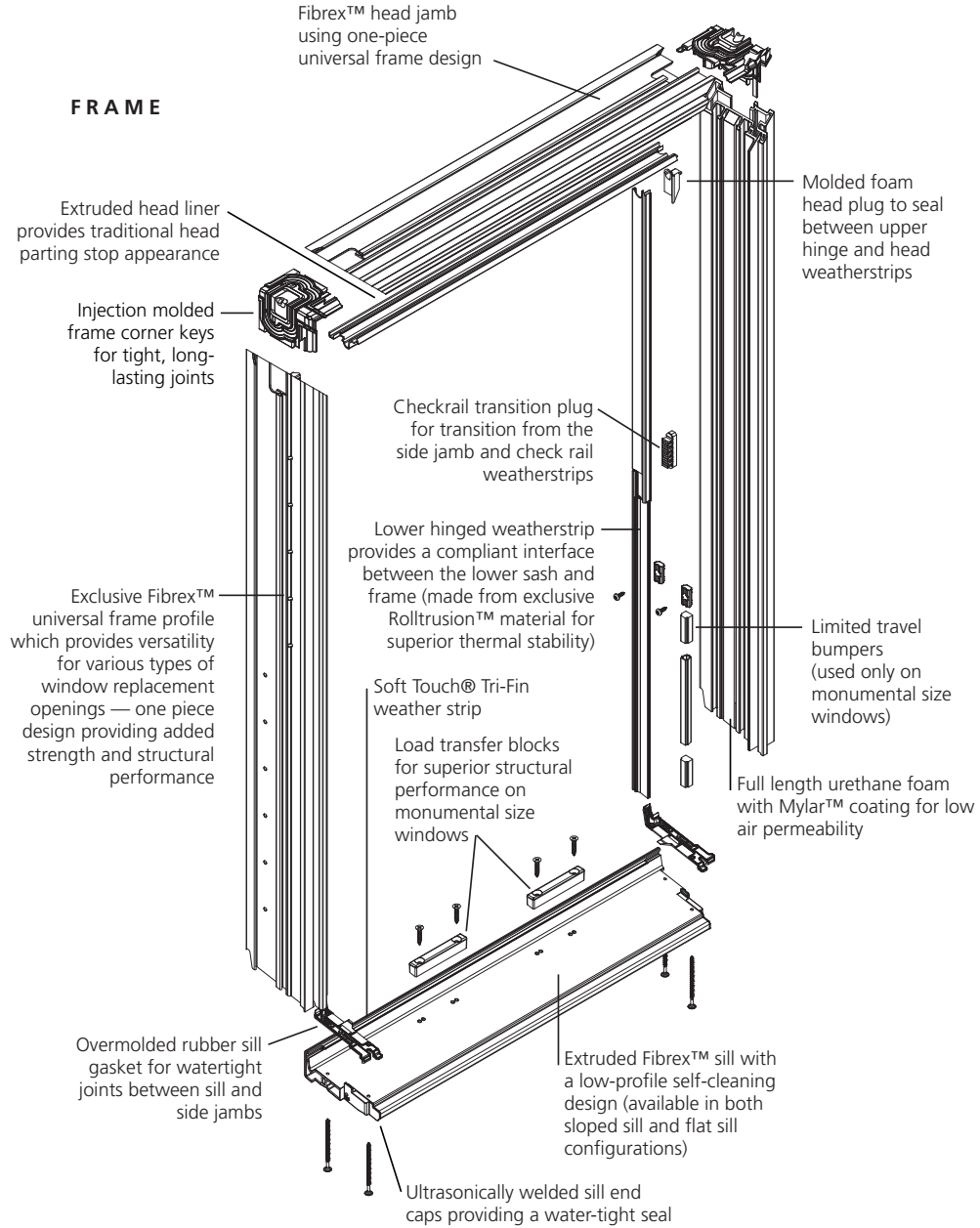

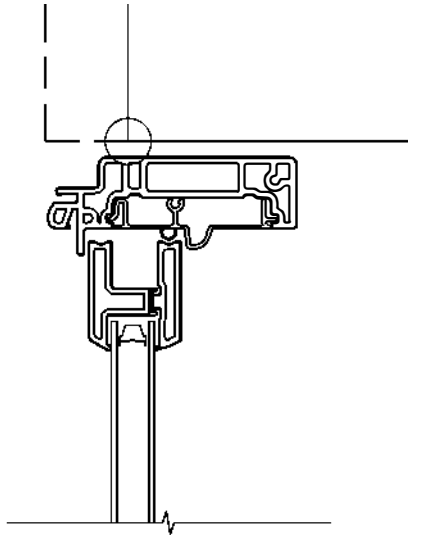
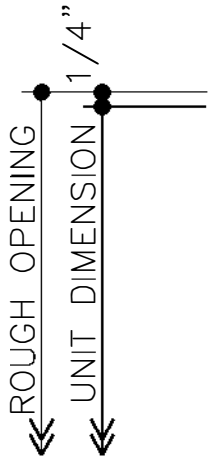

HEAD

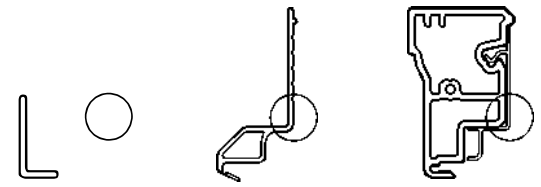

L-TRIM

OVERFIT TRIM

INSERT
BRICKMOULD

INSERT OPTIONAL COMPONENT AT CENTER OF CIRCLE

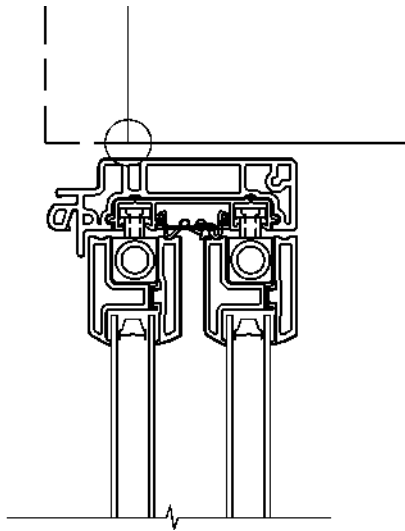
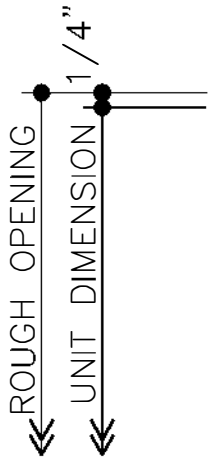

JAMB

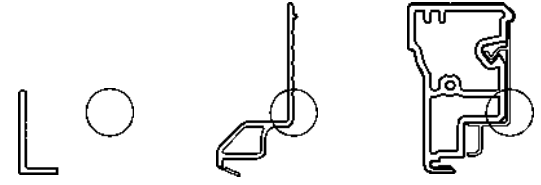

L-TRIM

OVERFIT TRIM

INSERT
BRICKMOULD

INSERT OPTIONAL COMPONENT AT CENTER OF CIRCLE

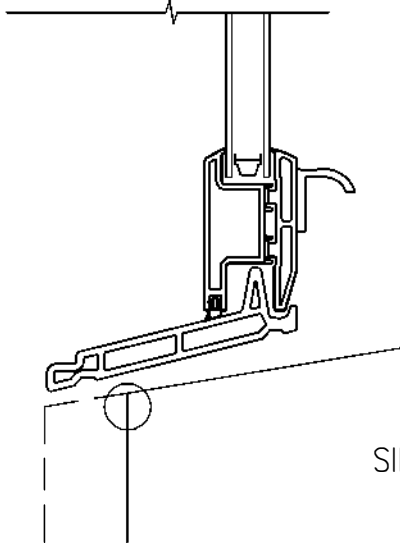

SILL

RENEWAL BY ANDERSEN®

SLOPE SILL INSERT DOUBLE-HUNG WINDOW DETAILS

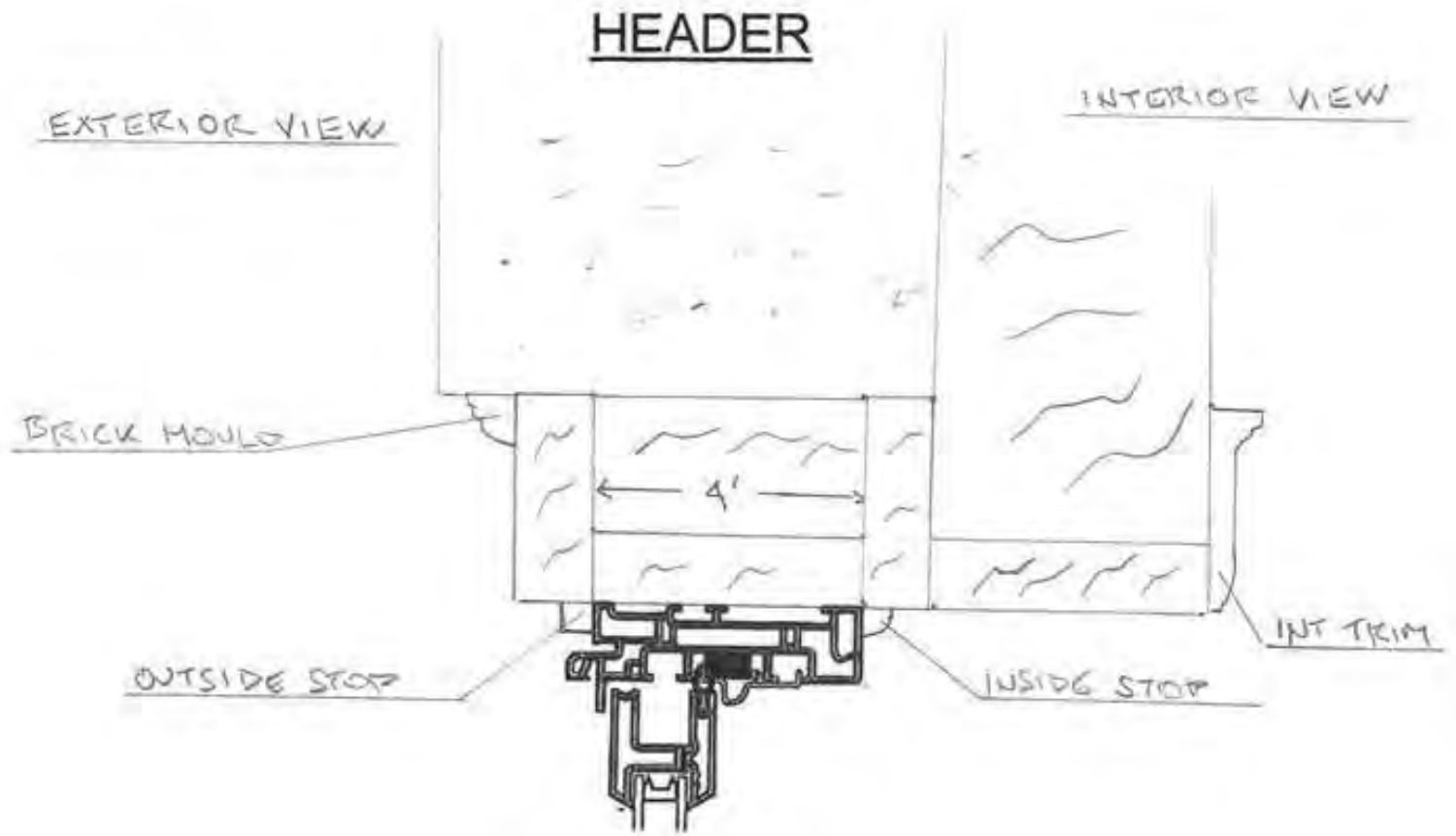

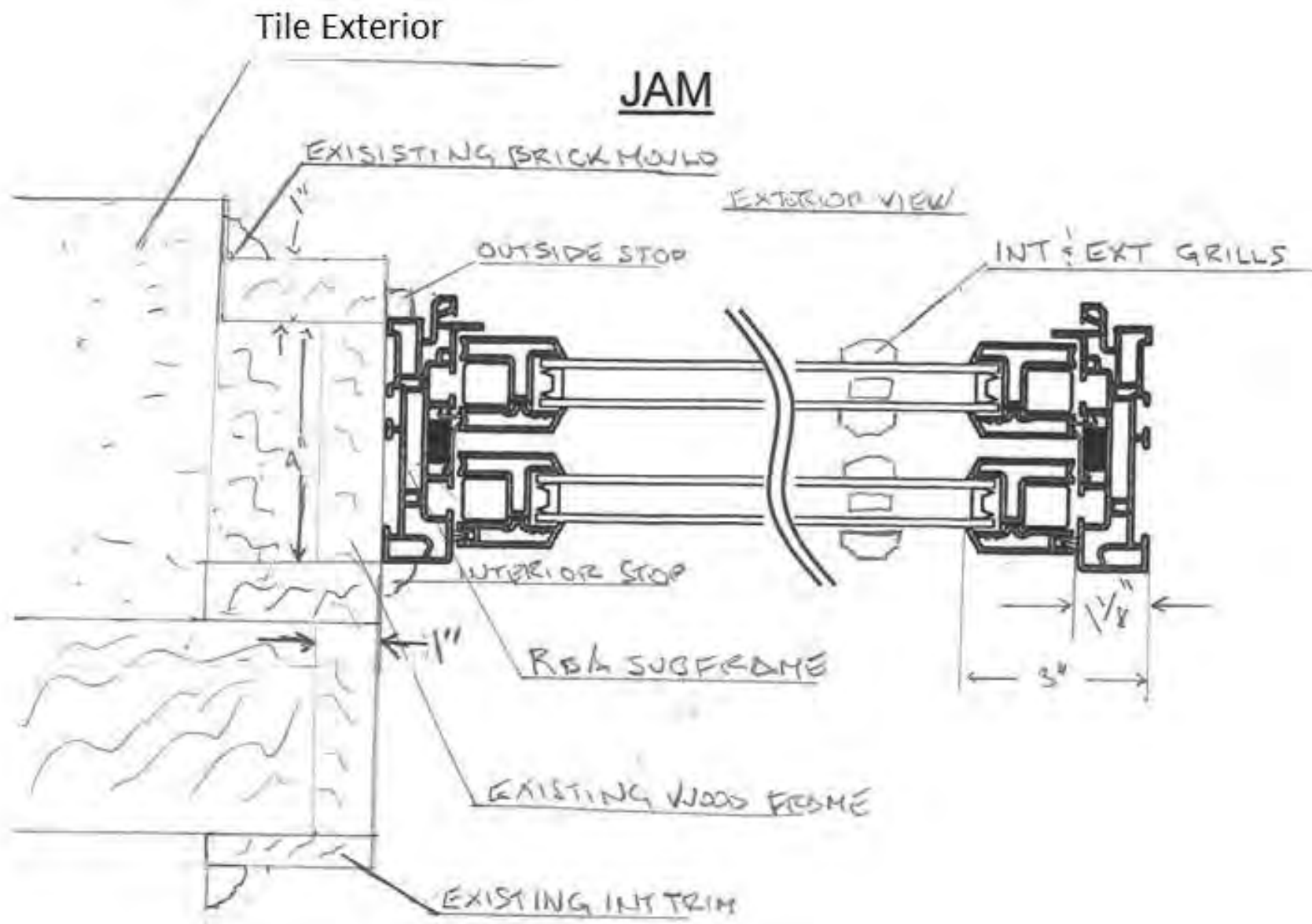

SILL

EXTERIOR VIEW

INTERIOR VIEW

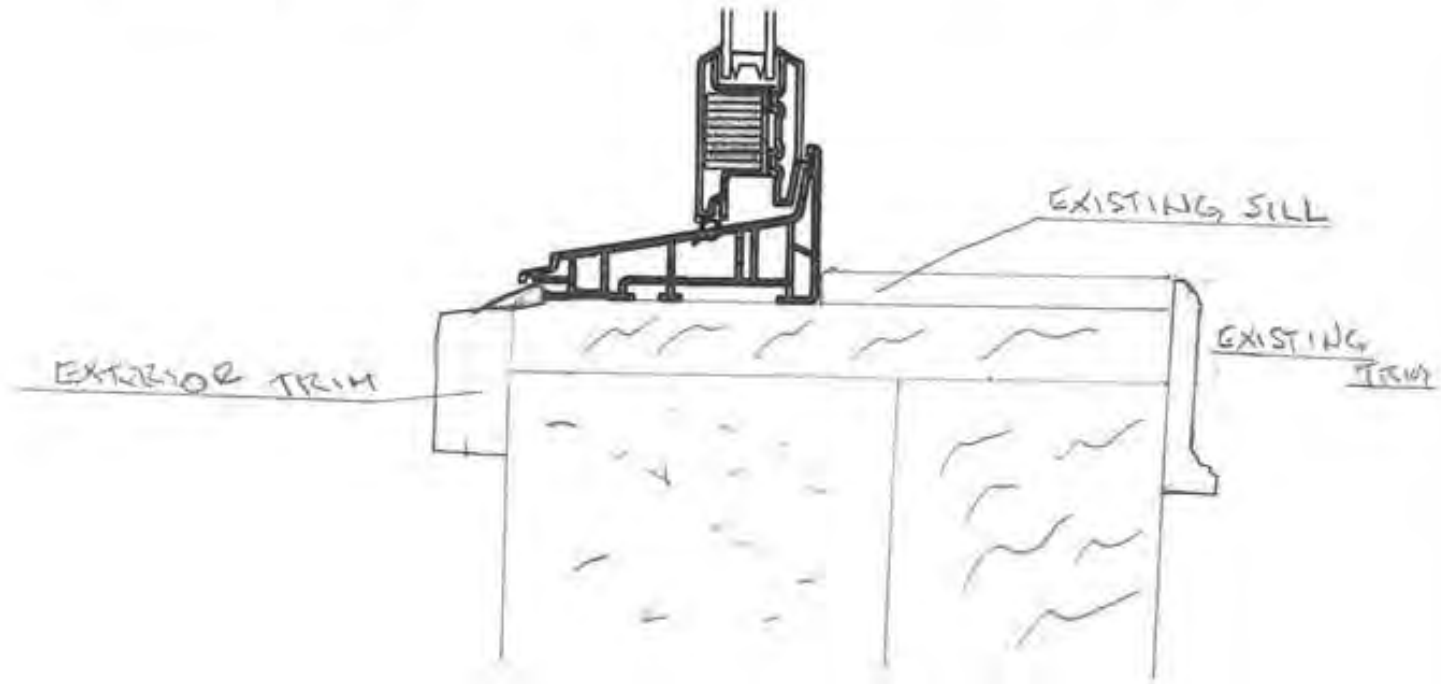

Choosing Renewal by Andersen® Windows is Easy...

We make it easy so you can sit back and relax, knowing you've selected a professional start-to-finish window replacement company.

The Renewal by Andersen process starts with our consultative sales approach. Our experienced sales representatives will work with you to find solutions to enhance your home's functionality, energy efficiency, and beauty.

1 Select Window Styles

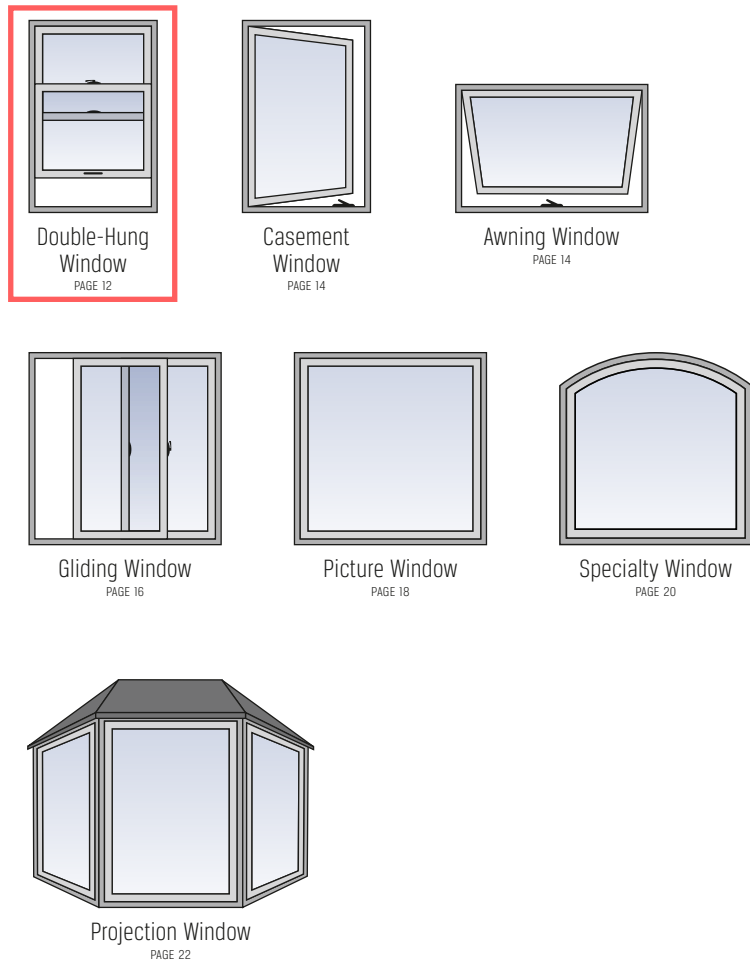

2 Select Colors³

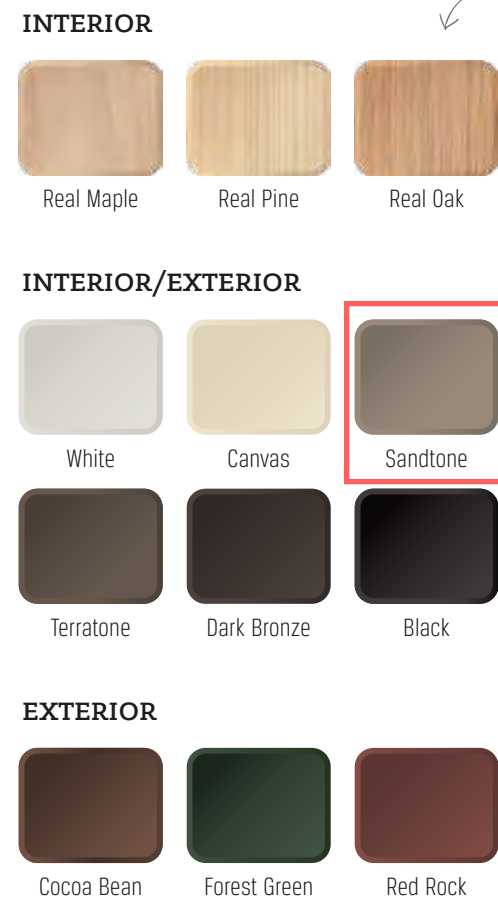

3 Select Hardware and Options



Visit Us Online at RENEWALBYANDERSEN.COM

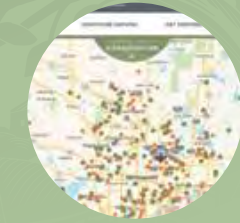

See independent homeowner reviews and completed projects from your neighborhood.

Explore how new windows will look in your home.



Get ideas and be inspired by our window options.

Five Key Environmental and Energy Solutions

While we care about you and your home, we also care deeply for the world in which we all live.



See our Environmental and Energy Solutions Brochure for additional information.

Grille OPTIONS

Whether it's for historical accuracy or creating an eye-catching new look, window grilles create instant curb appeal.

Customize Your Windows

Renewal by Andersen offers a wide range of creative grille patterns to enhance the look of your home.

All of our grilles are designed to be long lasting¹ with low-maintenance performance. With such a broad range of high-profile grille options, you can match your home's current architecture, change the look and style of your home, or incorporate them into a renovation project for historical accuracy.

Patterns

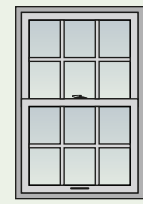

Colonial

Specified number of squares per sash.

Double-hung window shown

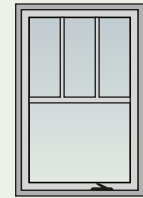

Farmhouse

Two vertical bars meet a wider horizontal rail or bar at the center of the window.

Casement window shown



Prairie

Two vertical and two horizontal bars per sash to form 4-inch corner squares.

Double-hung window shown

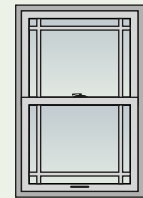

Modified Prairie

Two vertical bars and one horizontal bar per sash.

Double-hung window shown

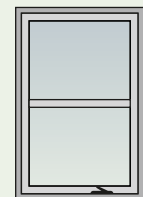

Simulated Double-Hung

Preserve the look of a traditional window.

Casement window shown

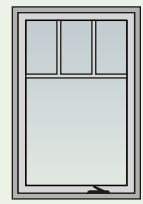

Fractional

Specified number of vertical bars meet a horizontal bar.

Casement window shown

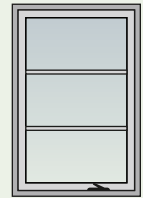

Equal Light

Specified number of horizontal bars, equal distance apart.

Casement window shown



Custom

Create a new pattern or revive one from the past.

Casement window shown



More

Ask your design consultant for more grille options.

Picture window shown

Profiles

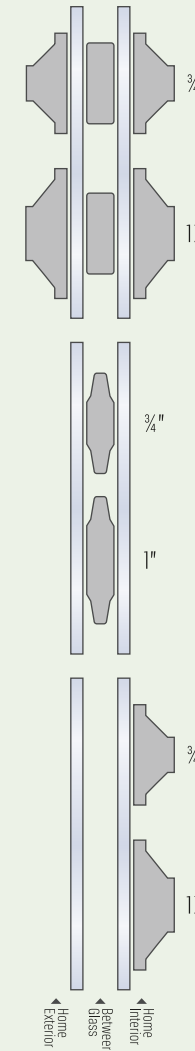
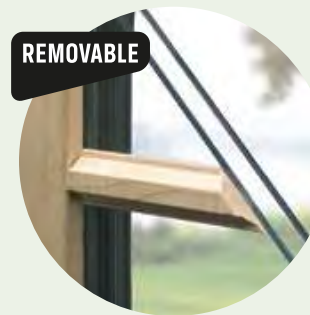

Full Divided Light Grilles

Full divided light grilles provide a visual representation of true divided glass. The option consists of a permanently applied exterior Fibrex® material grille, an aluminum spacer between the glass, and a removable or permanently applied interior grille. Available in two widths and an array of colors.

Grilles Between-the-Glass

Aluminum grilles are permanently installed between the panes during manufacturing, providing the beauty of grilles with the quick cleaning of a smooth glass surface. Available in two widths and an array of colors.

Interior Wood Grilles

Made of hardwood, these grilles snap into clips on the interior of the sash and can be easily removed to make glass cleaning a breeze. Available in two widths.



Picture Windows / Pine Interior / Colonial Grilles



Double-Hung and Casement Windows / White Exterior / Colonial Grilles



Casement Window / White Interior / Prairie Grilles



Double-Hung Window
Black Exterior / Custom Grilles

Insect Screen OPTIONS

Even when it comes to insect screens, you can let your personal style guide you.

Repel Invaders

Fiberglass insect screens are included with every operable window from Renewal by Andersen. Each is lightweight and designed to be easily removed from the inside of your home for easy cleaning. All insect screens are constructed with an aluminum frame and your choice of fiberglass, aluminum, or our innovative TruScene insect screens. Half insect screens are available on double-hung windows.



High Transparency



TruScene® Insect Screen

With over 50% more clarity than our standard insect screen,⁹ it's virtually invisible. TruScene insect screens are made with a micro-fine stainless steel mesh that's one-third the diameter of standard screen wire.⁹ That lets more fresh air and sunlight in while keeping most of the smallest insects out.

- Lets more light in
- Superior ventilation
- Protection against some of the smallest insects
- Patented technology



Wood-Veneered TruScene Insect Screen

Our wood-veneered TruScene insect screen blends seamlessly into the window frame and can be stained or painted to match your decor. Available on casement and awning windows only.



TruScene® Insect Screen



TruScene insect screens are like nothing you've ever seen!



Conventional

Fiberglass Insect Screen

Fiberglass is the most common type of insect screen. It is strong and keeps the majority of bugs out while allowing plenty of air flow.



Aluminum Insect Screen

Our aluminum insect screen has a charcoal powder coating to reduce glare and increase visibility. It is also strong and has good ventilation and corrosion resistance.



Hardware Finish OPTIONS

Sophistication...a whisper of style and confidence.

Define Your Style

Not only does Renewal by Andersen® hardware function well, its metal construction is also long lasting.¹ With multiple color options,³ you can match your home's existing colors or change the look by choosing a new color that complements your new windows.

With so many design options, you can create the windows you've always wanted with the design features that are right for you and your home.

Do you want to make your mark? With our Estate Hardware metal finishes, explore the many creative possibilities sure to add charm to your home that others will notice!

Andersen EXCLUSIVE FEATURE Estate™ Hardware



ESTATE HARDWARE

Standard Hardware



Nesting handles reduce interference with window treatments



Estate Double-Hung Hand Lift / Bright Brass Finish



Estate Casement and Awning Window Handle / Antique Brass Finish



Estate Double-Hung Finger Lift / Bright Brass Finish



Estate Double-Hung Window Latch / Satin Nickel Finish



Double-Hung Window Latch / White Finish



Estate Casement Window Latch / Antique Brass Finish



Estate Gliding Window Latch / Distressed Nickel Finish

⁹ Comparison made to a standard Renewal by Andersen aluminum insect screen.

¹⁰ Features special coating to seal the finish, providing tarnish and corrosion protection.

¹¹ Features "living" finish, where the patina changes with time and use.

Feel Confident Entrusting Your Home to the Masters



We work with the best people across the board. Rigorously trained, respectful, and friendly, you'll see why we're proud to call them Certified Master Installers.



A QUALITY EXPERIENCE IS IN THE DETAILS

We've long understood that all the care, pride, and craftsmanship we put into our products would mean little without professional installation. It's from these standards that we created our Certified Master Installer program.



WE TAKE A UNIQUE APPROACH

Not only do we provide a quality, professional process from start to finish, our Certified Master Installer program takes this to the next level by placing your new windows and patio doors in the hands of skilled Master Installers with years of experience.



OUR STANDARDS ARE TOUGH

Prior to certification, we require all trainers and installers at our certified locations to demonstrate their knowledge of construction materials, building codes, and installation methods. We understand you work hard for your home, and we want you to be as comfortable as possible throughout the installation process.



ONLY THE BEST PEOPLE MAKE THE CUT

We take pride in setting the highest standards in the market, with no stone left unturned. This includes the men and women installing your windows. We're proud to put our name in their hands.



Thanks to meticulous training, extensive supervision, and high expectations, our Certified Master Installers are without a doubt the best team for the job – the team we trust to handle the windows built just for you.



What are Renewal by Andersen® windows made of?

All of our windows are made of Fibrex® material, a revolutionary composite made from reclaimed wood fiber blended with a polymer. This gives our windows the strength and durability of wood and the low-maintenance features of vinyl, while greatly limiting thermal transmittance that can be found in other window materials such as metal.

Unlike many other window materials, Fibrex composite material won't flake, rust, blister, peel, crack, pit, or corrode.¹ It is also two times stronger than vinyl and resists warping and bowing. Never worry about scraping or painting your windows again.

ENGINEERED WITH
FIBREX®
MATERIAL

Andersen
EXCLUSIVE
FEATURE

SMART MATERIALS

Fibrex material is twice as strong as vinyl, so weathertight seals stay weathertight.

COLOR CHOICE

Our unique process fuses color to Fibrex material for long-lasting beauty. And it offers dark exterior colors not available on most other replacement windows.

EXCEPTIONAL COMFORT

Fibrex material blocks thermal transfer nearly 700 times better than aluminum to help reduce heating and cooling bills.

OUTSTANDING DURABILITY

Fibrex material retains its stability and rigidity in all climates!

	FIBREX MATERIAL	VINYL	ALUMINUM	WOOD
Insulating Properties	✓	✓		✓
Low Maintenance	✓	✓	✓	
Resistance to Decay/Corrosion	✓	✓		
Structural Rigidity	✓		✓	✓
Durability	✓		✓	✓
Color Choices	✓			✓
Dark Color Performance	✓		✓	✓



CERTIFICATE OF LIABILITY INSURANCE

DATE (MM/DD/YYYY)

1/3/2024

THIS CERTIFICATE IS ISSUED AS A MATTER OF INFORMATION ONLY AND CONFERS NO RIGHTS UPON THE CERTIFICATE HOLDER. THIS CERTIFICATE DOES NOT AFFIRMATIVELY OR NEGATIVELY AMEND, EXTEND OR ALTER THE COVERAGE AFFORDED BY THE POLICIES BELOW. THIS CERTIFICATE OF INSURANCE DOES NOT CONSTITUTE A CONTRACT BETWEEN THE ISSUING INSURER(S), AUTHORIZED REPRESENTATIVE OR PRODUCER, AND THE CERTIFICATE HOLDER.

IMPORTANT: If the certificate holder is an ADDITIONAL INSURED, the policy(ies) must have ADDITIONAL INSURED provisions or be endorsed. If SUBROGATION IS WAIVED, subject to the terms and conditions of the policy, certain policies may require an endorsement. A statement on this certificate does not confer rights to the certificate holder in lieu of such endorsement(s).

PRODUCER Cross Insurance, Inc. - RI 376 Newport Avenue P. O. Box 4830 E. Providence RI 02916	CONTACT NAME: Lisa Glasberg PHONE (A/C, No, Ext): 401-431-9200 E-MAIL ADDRESS: lisa.glasberg@crossagency.com	FAX (A/C, No): 401-431-9201	
	INSURER(S) AFFORDING COVERAGE		
INSURED J&M Windows, Inc. dba Renewal by Andersen of Greater Philadelphia 761 5th Ave #3 King of Prussia PA 19406	476729	INSURER A : Acadia Ins Co. INSURER B : INSURER C : INSURER D : INSURER E : INSURER F :	NAIC # 31325

COVERAGES

CERTIFICATE NUMBER: 1710684689

REVISION NUMBER:

THIS IS TO CERTIFY THAT THE POLICIES OF INSURANCE LISTED BELOW HAVE BEEN ISSUED TO THE INSURED NAMED ABOVE FOR THE POLICY PERIOD INDICATED. NOTWITHSTANDING ANY REQUIREMENT, TERM OR CONDITION OF ANY CONTRACT OR OTHER DOCUMENT WITH RESPECT TO WHICH THIS CERTIFICATE MAY BE ISSUED OR MAY PERTAIN, THE INSURANCE AFFORDED BY THE POLICIES DESCRIBED HEREIN IS SUBJECT TO ALL THE TERMS, EXCLUSIONS AND CONDITIONS OF SUCH POLICIES. LIMITS SHOWN MAY HAVE BEEN REDUCED BY PAID CLAIMS.

INSR LTR	TYPE OF INSURANCE	ADDL INSD	SUBR WVD	POLICY NUMBER	POLICY EFF (MM/DD/YYYY)	POLICY EXP (MM/DD/YYYY)	LIMITS
A	<input checked="" type="checkbox"/> COMMERCIAL GENERAL LIABILITY <input type="checkbox"/> CLAIMS-MADE <input checked="" type="checkbox"/> OCCUR GEN'L AGGREGATE LIMIT APPLIES PER: <input type="checkbox"/> POLICY <input checked="" type="checkbox"/> PRO-JECT <input type="checkbox"/> LOC <input type="checkbox"/> OTHER:			CPA5534384	1/1/2024	1/1/2025	EACH OCCURRENCE \$ 1,000,000 DAMAGE TO RENTED PREMISES (Ea occurrence) \$ 300,000 MED EXP (Any one person) \$ 10,000 PERSONAL & ADV INJURY \$ 1,000,000 GENERAL AGGREGATE \$ 2,000,000 PRODUCTS - COMP/OP AGG \$ 2,000,000 \$
A	<input checked="" type="checkbox"/> AUTOMOBILE LIABILITY <input checked="" type="checkbox"/> ANY AUTO <input type="checkbox"/> OWNED AUTOS ONLY <input type="checkbox"/> SCHEDULED AUTOS <input type="checkbox"/> HIRED AUTOS ONLY <input type="checkbox"/> NON-OWNED AUTOS ONLY			CAA5534385	1/1/2024	1/1/2025	COMBINED SINGLE LIMIT (Ea accident) \$ 1,000,000 BODILY INJURY (Per person) \$ BODILY INJURY (Per accident) \$ PROPERTY DAMAGE (Per accident) \$ \$
A	<input checked="" type="checkbox"/> UMBRELLA LIAB <input type="checkbox"/> EXCESS LIAB <input type="checkbox"/> DED <input type="checkbox"/> RETENTION \$			CUA5534402	1/1/2024	1/1/2025	<input type="checkbox"/> OCCUR <input type="checkbox"/> CLAIMS-MADE EACH OCCURRENCE \$ 10,000,000 AGGREGATE \$ 10,000,000 \$
A	WORKERS COMPENSATION AND EMPLOYERS' LIABILITY ANY PROPRIETOR/PARTNER/EXECUTIVE OFFICER/MEMBER EXCLUDED? (Mandatory in NH) If yes, describe under DESCRIPTION OF OPERATIONS below	Y/N	N/A	WCA5534403	1/1/2024	1/1/2025	<input checked="" type="checkbox"/> PER STATUTE <input type="checkbox"/> OTHER E.L. EACH ACCIDENT \$ 1,000,000 E.L. DISEASE - EA EMPLOYEE \$ 1,000,000 E.L. DISEASE - POLICY LIMIT \$ 1,000,000

DESCRIPTION OF OPERATIONS / LOCATIONS / VEHICLES (ACORD 101, Additional Remarks Schedule, may be attached if more space is required)

CERTIFICATE HOLDER**CANCELLATION**

Evidence of Insurance	SHOULD ANY OF THE ABOVE DESCRIBED POLICIES BE CANCELLED BEFORE THE EXPIRATION DATE THEREOF, NOTICE WILL BE DELIVERED IN ACCORDANCE WITH THE POLICY PROVISIONS.
	AUTHORIZED REPRESENTATIVE

© 1988-2015 ACORD CORPORATION. All rights reserved.



City of Philadelphia
Department of
Licenses & Inspections
P.O. Box 53310
Philadelphia, Pa. 19105

DISPLAY PROMINENTLY
if required by law

J & M WINDOWS INC
761 5TH AVENUE
SUITE 3
KING OF PRUSSIA, PA 19406
USA

3527 Contractor

J & M WINDOWS INC

THIS LICENSE IS GRANTED TO THE PERSON OR COMPANY FOR THE PURPOSE STATED ABOVE. IT IS SUBJECT TO IMMEDIATE CANCELLATION BY THIS DEPARTMENT FOR VIOLATIONS OF CITY ORDINANCES AND REGULATIONS.

LICENSE CODE	LICENSE NO.	COMMERCIAL ACTIVITY LIC.	EXPIRES ON	ISSUED ON
3527	37492	480754	3/30/2024	3/7/2023

LIMITS & CONDITIONS:

1. Contractors and subcontractors (including individuals and business entities) must have valid licenses. All subcontractors working under a permit must be submitted to the Department.
2. Contractors cannot sell or transfer their license or permit to another person.
3. Contractors must provide accurate information on any license or permit application with the Department.
4. Contractors must get all required permits for construction work and comply with approved permit documents.
5. Contractors must maintain information at each job site as required by the Philadelphia Code.
6. Contractors must display their Contractor License number on any advertisements, stationery, places of business, job sites, proposals, and vehicles displaying the business name.
7. Contractors must maintain complete financial and construction records (including plans) for each job performed for four years after completion of the job.
8. Contractors must follow all provisions of The Philadelphia Code.

LICENSE

🗑️ Delete
📁 Archive
↩️
↶
↷
🔍 Zoom
✉️
🏷️
🚩
🖨️
⋮

Re: Window Application at 310 S. 16th St

JS James Sirio <jsirio@renewalphilly.com> 📧 ↩️ Reply ↶ Reply all ↷ Forward 🔗 👁️ ⋮
 To: Daniel Shachar-Krasnoff
 Cc: Maggie McDewitt <MMcDevitt@renewalphilly.com> Fri 10/18/2024 10:16 AM

🚩 **Flagged**

🕒 Retention: 50 Day Inbox Purge - Allow Dumpster Recovery (4 months) Expires: Sat 2/15/2025 9:16 AM

Start reply with:

External Email Notice. This email comes from outside of City government. Do not click on links or open attachments unless you recognize the sender.

Hi Daniel,
 Apologies for my delayed response. Here are some clarifications:

Is the existing frame being removed? We only have this in the contract because the commission does not allow a new frame inside the existing original frame. The only way then to get the existing wood frame out would be to full tear the window. Whatever we need to do, is what we will do. Should the commission require a full tear, we will replicate exactly what is there. Should they allow us to install our window as an insert, then there will be glass loss but the existing frame will remain intact. My guess, being new to this, would be the commission would support the replacement of the frame as to maintain the look it has existing now. Either way, we will do what needs to be done for approval.

Brickmold - again, this is more dependent on what the commission wants the final product to look like. The brickmold and framing of the window are easy to replicate. The major issue seems to be the composite material of our frame versus that of a historic wood window

Screens - yes, the windows come standard with screens. However, if that becomes a deal breaker, the homeowner has agreed to remove and store the screens.

Generally speaking, all of these issues can be clearly hashed out in the meeting on Tuesday. We will commit to making the adequate adjustments for approval regarding the full tear/insert, clam brickmold etc. Mainly though, our goal is to focus on the fibrex frame and ensure that the commission recognizes the importance of this frame for the homeowner and the longevity of the product. For this, I have attached some photos below that show how the Andersen Fibrex has no recognizable differences to a wood window.

Please, let me know what more I can clarify for you in preparation for the meeting.

Kindly

James Sirio
 Project Consultant
 412-337-7082

