

PROPOSED SIGNAGE IS FOR 1 SIGN:
SIGN 1 IS A PROJECTING BACKLITE, DOUBLE SIDED SIGN, WITH A BRASS FRAME AND BRACKET.

1 PROJECTED SIGN ALLOWED
261.96 SF OF SIGNAGE ALLOWED.

SIGN	CHARACTERISTICS	TYPE	AREA
SIGN 1	STATIC ILLUMINATED BACKLITE	PROJECTING	8.13 SF
TOTAL AREA:			8.13 SF

ASSIMILATION DESIGN LAB LLC
515 S 48TH ST
PHILADELPHIA, PA 19143
DAVID WHIPPLE
C: 267.918.1354
E: DFW@ASSIMILATIONDESIGNLAB.COM
ARCHITECT

SEAL

1602-04 LOCUST STREET ASS
1602-04 LOCUST ST
PHILADELPHIA PA 19103-6305
DAVID SURO
T: 215.939.3496
E: DAVIDGSURO@GMAIL.COM
OWNER

JDM ENGINEERING LLC
815 RT 54
WILLIAMSTOWN, NJ 08094
MIKE MOTA
T: 856.264.3851
E: mikemota@gmail.com
STRUCTURAL ENGINEER

HUTEC ENGINEERING INC
304 MASTER ST, 1ST FLOOR
PHILADELPHIA, PA 19122
T: 267.800.3540
E: info@huteceengineering.com
STRUCTURAL ENGINEER

REVISIONS		
1	07.01.24	PERMIT SET
2	07.24.24	PERMIT SET
3	07.29.24	PERMIT SET

CONSTRUCTION SET

1602-04 LOCUST

1602-04 LOCUST ST
PHILADELPHIA, PA 19103

PROJECT

SIGNAGE DRAWINGS

SHEET TITLE
PROJECT NUMBER - 516

SCALE:	SHEET No.
AS NOTED	
DRAWN BY: DFW	A-003
CHECKED BY: DFW	
FILE:	

Sara Casillas Pereyra
 +52 (33)1991 3121
 hola@sedestudio.com
 www.sede-studio.com
 @sede_studio

032 TEQUILAS
 CLIENTE ...
 UBICACIÓN PHILADELPHIA, PA.

TÍTULO
032_LETRERO

PLANO
000

ESPECIFICACIONES

-Estructura en cobre

NOTAS

-Calibre del cobre SMA
 -Tipografía SMA

NORTE

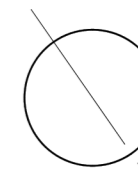

ESCALA	FASE
N/A	ANT

DIBUJÓ	REVISÓ
ARM	...

AUTORIZÓ
 ...

FECHA
29/07/24



REFERENCE IMAGE

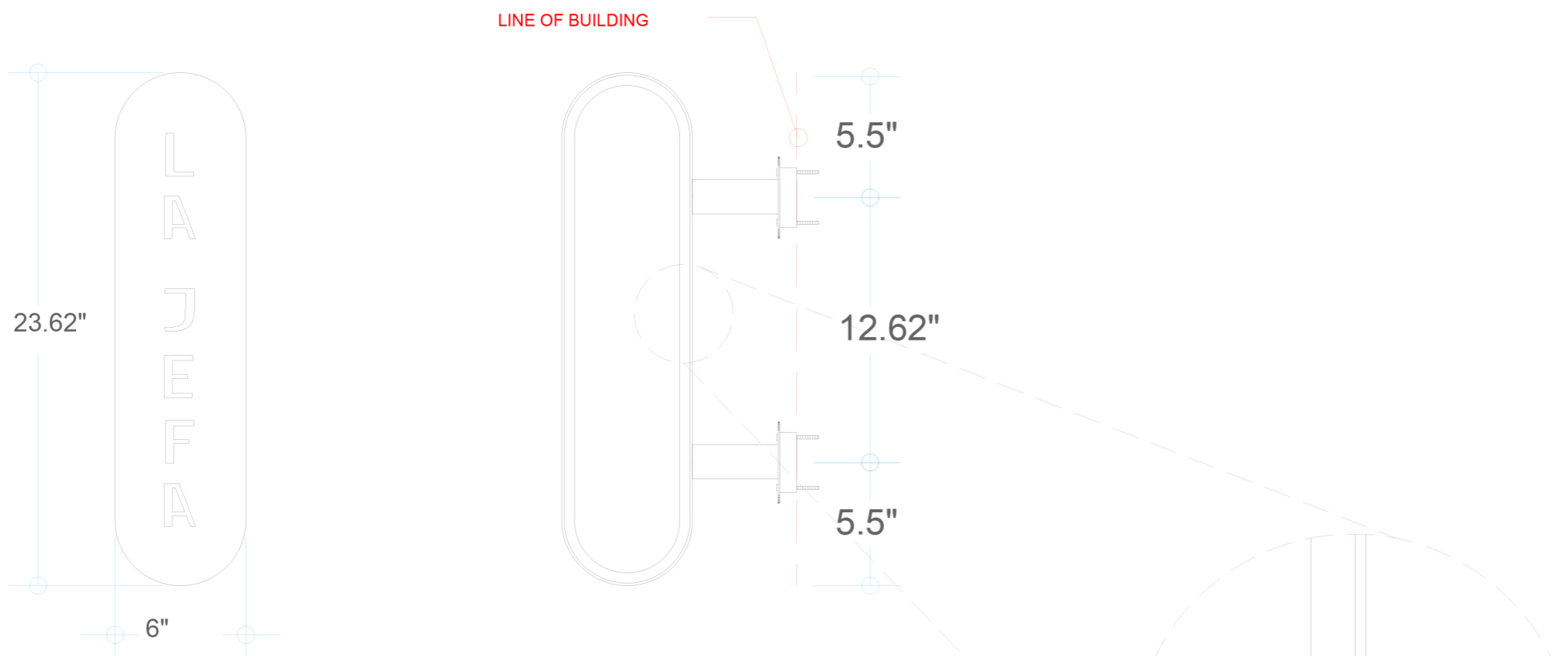

SIGN DETAIL - FRONT

SIGNAGE DETAIL- FRONT

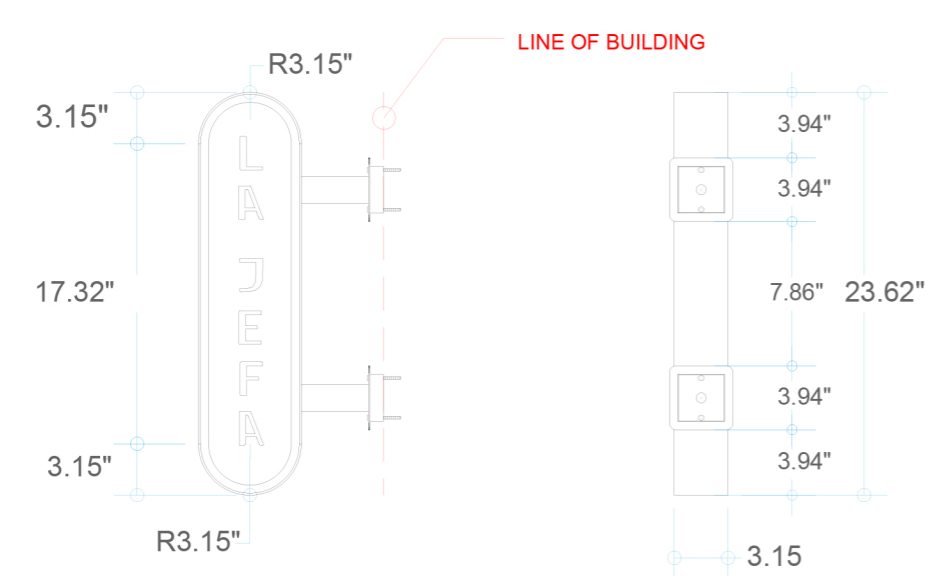

SIGN - FRONT

SIGN - SECTION

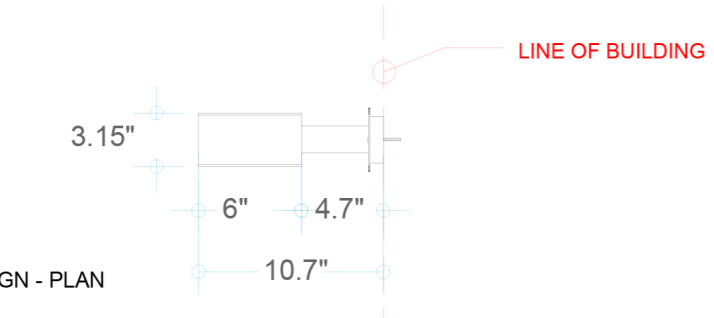

SIGN - PLAN

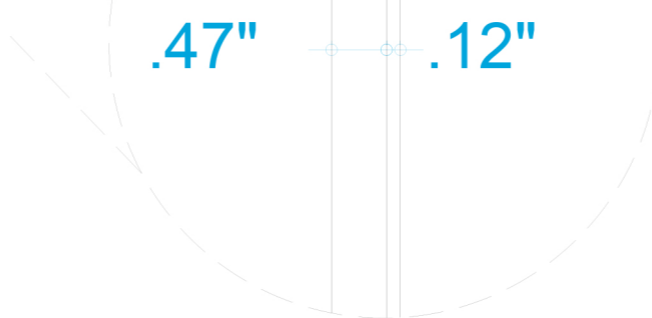

BRACKET DETAILS

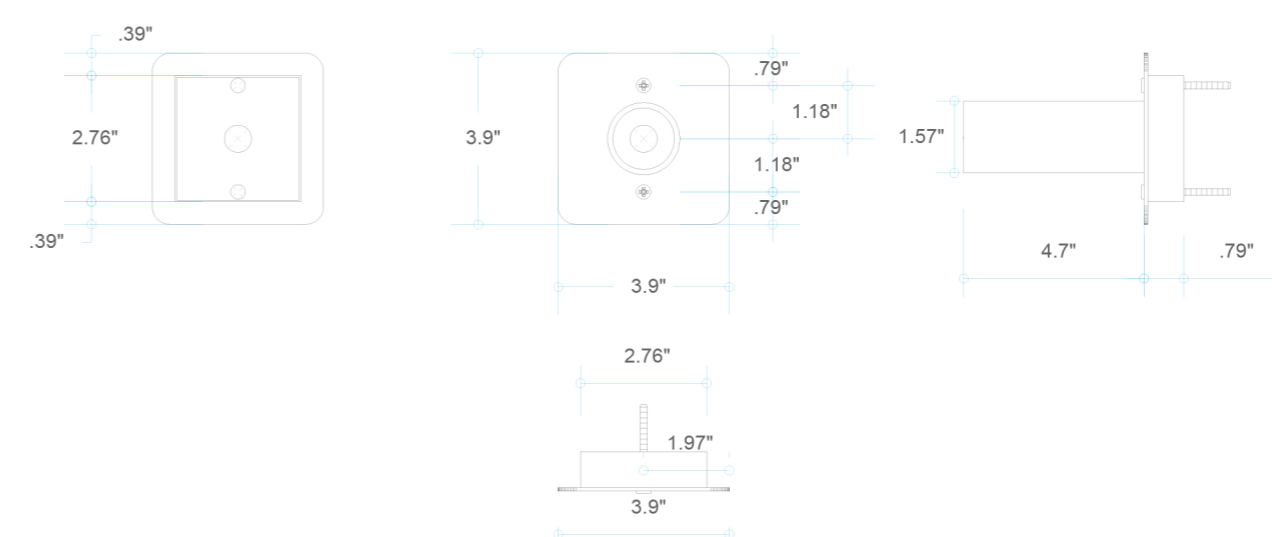



1602 Locust St
Philadelphia PA